

Butterfly Valve

ISORIA 20

Centred-disc Butterfly Valve
AMRING Elastomer Liner
DN 32-600
PS 20 bar

Type Series Booklet



Legal information/Copyright

Type Series Booklet ISORIA 20

All rights reserved. The contents provided herein must neither be distributed, copied, reproduced, edited or processed for any other purpose, nor otherwise transmitted, published or made available to a third party without the manufacturer's express written consent.

Subject to technical modification without prior notice.

© KSB S.A.S, Gennevilliers (Paris), France 12.05.2015

Butterfly Valves

Centred-disc Butterfly Valves

ISORIA 20



Main applications

- Cooling circuits
- Seawater desalination/reverse osmosis
- Flue gas desulphurisation
- Paper and cellulose industry
- Washing plants
- General irrigation systems
- Shipbuilding
- Pipelines and tank farms
- Process engineering
- Sugar industry
- Pressure boosting
- Water treatment/conditioning

Fluids handled

- Wash water
- Seawater
- Service water
- Cooling water
- Fire-fighting water
- Drinking water
- Brackish water
- River, lake and groundwater
- Abrasive fluids
- Fluids containing mineral oils
- Solids-laden fluids
- Organic fluids
- Radioactive fluids

- Solvents

Operating data

Operating properties

Characteristic	Value
Nominal pressure	PN 20
Nominal size	DN 32-600
Max. permissible pressure	20 bar
Max. permissible temperature	+80 °C
Min. permissible temperature	-10 °C
Actuation at ΔP	20 bar (max.) at ambient temperature
Suitable for vacuum applications down to	0.3 bar absolute
Max. permissible flow velocity at operating pressure	1.5 to 3 m/s (max.) for water

Design details

Design

- Semi-lug body - T2: DN 32 - 600
- Full-lug body with flat faces - T3: DN 32 - 600
- Full-lug body with raised faces - T4: DN 32 - 600
- Flanged body with flat faces - T5: DN 200 - 600
- Downstream dismantling possible with body types T2, T3, T4 and T5
- Dead-end service with counterflange possible with all body types
- Design to EN 593 and ISO 10631
- Top flange to ISO 5211
- Marked in accordance with EN 19
- Absolutely tight shut-off (no leakage visible to the naked eye) in either direction of flow in accordance with EN 12266-1, leakage rate A, and ISO 5208, category A.
- Face-to-face length to ISO 5752-20 and EN 558-1-20
- EN, ASME, JIS, AWWA connections possible.
- Body with polyurethane coating, thickness 80 μm , colour: RAL 5002, blue.
- Valve disc made of nodular cast iron, epoxy-coated, thickness 80 μm , colour: RAL 8012, brown
- The valves satisfy the safety requirements of Annex I of the European Pressure Equipment Directive 97/23/EC (PED) for fluids in Groups 1 and 2.
- Valves with actuators can meet the requirements of the 2006/42/EC Machinery Directive for partly completed machinery.
- The valves meet the requirements of the REACH 1907/2006 regulation. None of the substances listed in the candidate list and in Annex XIV of the regulation is present in a concentration above 0.1 % (w/w) (Article 33/REACH).

Variants

- Valve cleaned and packaged, free from substances which impair the adhesive strength of paint
- S / SR / SP / CR / CM quarter-turn levers
- MN / MR manual gearboxes
- ACTELEC electric actuators
- ACTAIR / DYNACTAIR pneumatic actuators

- ACTO/DYNACTO/ENNACTO hydraulic actuators
 - AMTROBOX control unit for position indication
 - AMTRONIC valve controller with compressed air supply via directional control valve
 - SMARTRONIC intelligent positioner
 - ATEX design in compliance with the 94/9/EC Directive
- 6. Temperature
 - 7. Materials (body, valve disc, seat)
 - 8. Line connection, flange facing and flange surface quality
 - 9. Actuator/automation
 - 10. Reference number of type series booklet

Body materials

Overview of available materials

Material	Material number	Type	DN (max.)	KSB code
EN-GJS-400-15	5.3106	T2	DN 32-600	3g
EN-GJS-400-15	5.3106	T3	DN 32-600	3g
EN-GJS-400-15	5.3106	T4	DN 32-600	3g
Cast steel	1.0619	T4	DN 32-600	1
EN-GJS-400-15	5.3106	T5	DN 350-600	3g
Cast steel	1.0619	T5	DN 200-600	1

Product benefits

- Spherically machined valve disc with rounded sealing contour
 - ensures durable and permanently tight shut-off
- Splined or keyed connection between stem and valve disc
 - Dry stem, no contact with fluid handled
- Sealing to atmosphere and tight shut-off are ensured,
 - even when the actuator has been removed
- Marking indicates position of valve disc
- Valve equipped with stainless steel bearings with reinforced PTFE coating
- The elastomer liner provides tight sealing at the flanged line connections, eliminating the need for a flange gasket.
- Valve certified to
 - ACS / DVGW / WRAS for drinking water applications, with XC elastomer liner
- Elastomer liner
 - EPDM - XC approved by KTW, ILP Nancy, WRC
- Valve actuation options:
 - Manual
 - Electric
 - Pneumatic
 - Hydraulic

Related documents

Other applicable documents

Document	Reference No.
Actuator selection	8446.11
Operating manual	8449.8

On all enquiries/orders please specify

1. Type series
2. Nominal pressure
3. Nominal size
4. Fluid handled
5. Flow rate/velocity

Technical data

Pressure limits of AMRING liners

DN	NPS	Max. permissible pressure PS [bar]	
		XA - XC - XV - K	
32-600	1¼-24	20	

Vacuum resistance

DN	NPS	Liner mounting method	Minimum pressure	Max. temperature	
			[bar absolute]	XV	Other
32-150	1¼-6	Non-glued (standard)	$1,33 \cdot 10^{-5}$ (10^{-2} torr)	80 °C	60 °C
200-600	8-24	Non-glued (standard)	0,3	80 °C	60 °C
200-600	8-24	Glued (optional)	$1,33 \cdot 10^{-5}$ (10^{-2} torr)	80 °C	60 °C

Hydraulic characteristics

DN	NPS	Flow coefficient with disc fully open		Zeta
		Kvo	Cvo	
32	1¼	30	35	1,44
40	1½	53	62	1,46
50	2	133	154	0,56
65	2½	240	280	0,49
80	3	410	475	0,39
100	4	655	760	0,37
125	5	900	1044	0,48
150	6	1800	2090	0,25
200	8	3550	4120	0,20
250	10	3890	4500	0,41
300	12	5580	6470	0,42
350	14	8060	9350	0,37
400	16	10500	12180	0,37
450	18	13300	15400	0,37
500	20	17400	20200	0,33
550	22	21000	24400	0,33
600	24	25000	29000	0,33

Actuating torques (in Nm)

A safety coefficient has already been included in the actuating torques for actuator selection.

DN	NPS	With lubricating fluids	With non-lubricating fluids
32	1¼	20	20
40	1½	20	20
50	2	30	30
65	2½	40	50
80	3	50	60
100	4	70	100
125	5	100	150
150	6	140	200
200	8	240	350
250	10	410	610
300	12	630	950
350	14	860	1300
400	16	1300	1900
450	18	1700	2500
500	20	2100	3100
550	22	2500	3700
600	24	2900	4300

Materials

DN 32-350

Sectional drawing

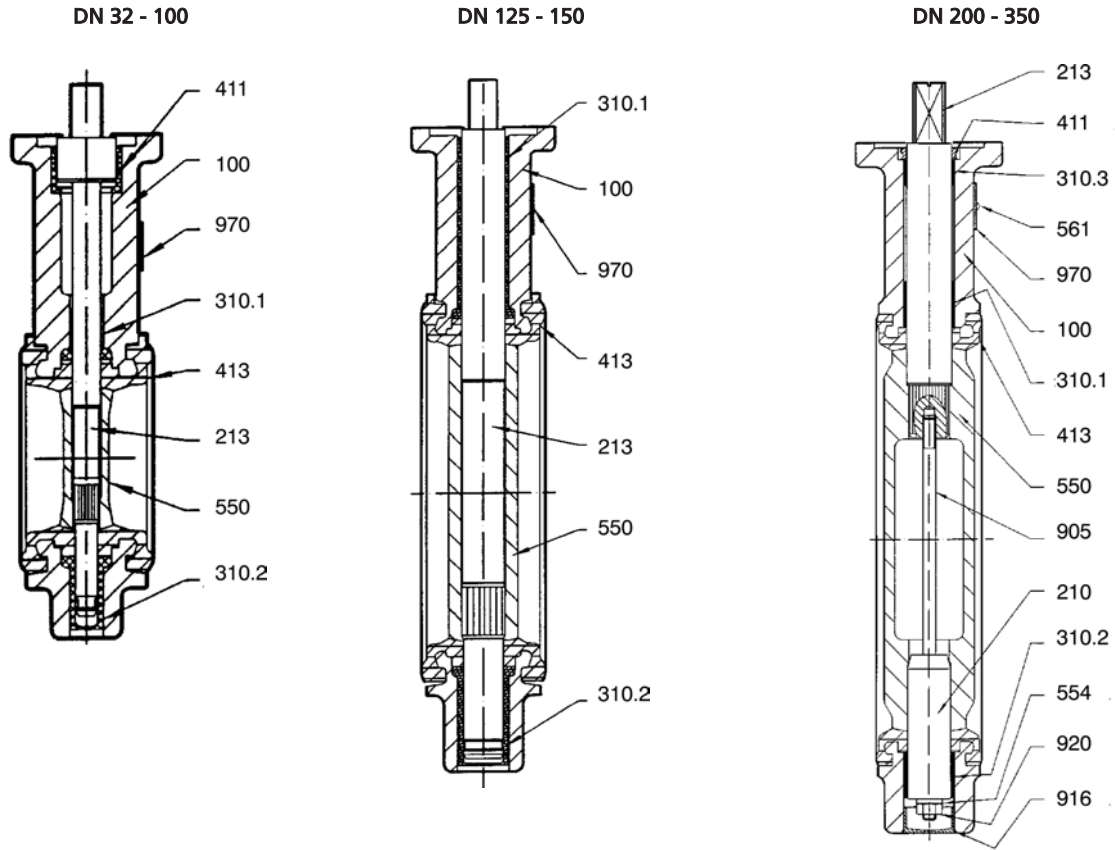

DN 400-600
Sectional drawing

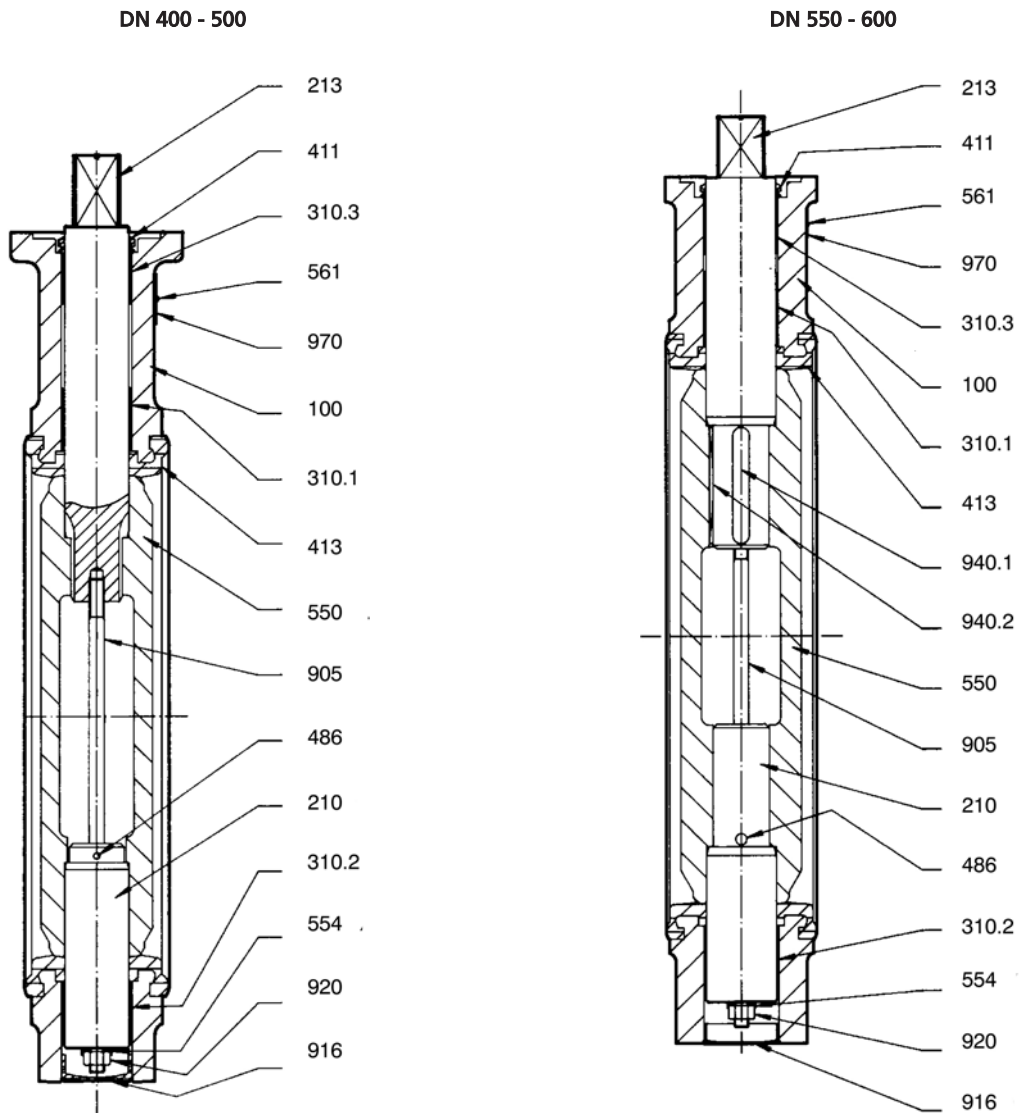

List of components

Part No.	Description	DN	Materials	KSB code
100	Body T2	32 - 600	Nodular cast iron 5.3106	3g
100	Body T3	32 - 600	Nodular cast iron 5.3106	3g
100	Body T4	32 - 600	Nodular cast iron 5.3106	3g
100	Body T4	32 - 600	Cast steel	1
100	Body T5	350 - 600	Nodular cast iron 5.3106	3g
100	Body T5	200 - 600	Cast steel	1
210 ¹⁾	Stem	200 - 600	Stainless steel 1.4057 (17 % Cr)	6e
210 ¹⁾	Stem	200 - 600	Nickel alloy MONEL K 500, tempered	
213 ¹⁾	Actuating stem	32 - 600	Stainless steel 1.4057 (17 % Cr)	6e
213 ¹⁾	Actuating stem	32 - 600	Nickel alloy MONEL K 500, tempered	
310.1 ¹⁾²⁾³⁾	Plain bearing	32 - 150	Acetal	
310.1 ¹⁾²⁾³⁾	Plain bearing	200 - 600	Steel with reinforced PTFE coating	
310.2 ¹⁾²⁾³⁾	Plain bearing	32 - 150	Acetal	
310.2 ¹⁾²⁾³⁾	Plain bearing	200 - 600	Steel with reinforced PTFE coating	
310.3 ¹⁾	Plain bearing	200 - 600	Steel with reinforced PTFE coating	
411 ¹⁾²⁾³⁾	Joint ring	32 - 100	Acetal	
411 ¹⁾²⁾³⁾	Joint ring	200 - 600	Nitrile	
413 ³⁾	Liner	32 - 600	EPDM	XA
413 ³⁾	Liner	32 - 600	EPDM suitable for drinking water	XC
413 ³⁾	Liner	32 - 600	EPDM, heat-resistant	XV
413 ³⁾	Liner	32 - 600	Nitrile HT	K
486	Ball	400 - 600	Stainless steel	
550 ²⁾	Valve disc	32 - 600	Nodular cast iron 5.3106	3g
550 ²⁾	Valve disc	32 - 600	Stainless steel 1.4408 (18-12) ASTM A351 Gr. CF8M	6
550 ²⁾	Valve disc	32 - 600	Stainless steel 1.4408 (18-12), polished, ASTM A351 Gr. CF8M	6i
550 ²⁾	Valve disc	32 - 600	Copper aluminium alloy CC333G	2
554	Washer	200 - 600	Nylon	
561	Half round head grooved pin	200 - 600	Stainless steel	
905	Tie bolt	200 - 600	Steel	
916 ¹⁾²⁾³⁾	Plug	200 - 500	Polyethylene	
916 ¹⁾²⁾³⁾	Plug	550 - 600	Polyamide	
920 ¹⁾	Nut	200 - 600	Steel	
940.1 ¹⁾	Key	550 - 600	Steel	
940.2 ¹⁾	Key	550 - 600	Steel	
970	Name plate	32 - 600	Stainless steel	

-
- 1) Included in stem spare parts kit
2) Included in valve disc spare parts kit
3) Included in liner spare parts kit
-

Dimensions

Drawings

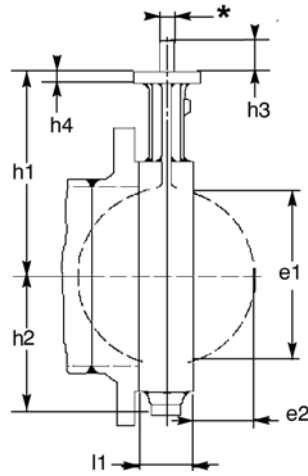

* Flat end s in $\varnothing z$ or $\varnothing s$

Dimensions

[mm]

DN	NPS	l1	h1	h2	Top flange to ISO 5211		Stem end Flat end			Stem end Square end		Valve disc	
					No.	h4	$\varnothing s$	$\varnothing z$	h3	$\varnothing s$	h3	e1	e2
32	1¼	33	109	54	F05	10	11	14	24	/	/	-	-
40	1½	33	105	58	F05	10	11	14	24	/	/	33	4
50	2	43	115	65	F05	10	11	14	24	/	/	38	4
65	2½	46	130	75	F05	10	11	14	24	/	/	55	10
80	3	46	135	95	F05	10	11	14	24	/	/	74	18
100	4	52	150	105	F05	10	14	18	24	/	/	92	25
125	5	56	165	124	F07	12	14	18	30	/	/	117	35
150	6	56	185	141	F07	12	14	18	30	/	/	143	48
200	8	60	218	172	F10	15	19	25	35	/	/	191	68
250	10	68	265	206	F10	15	19	25	35	/	/	241	89
300	12	78	306	236	F12	18	22	28	40	/	/	290	110
350	14	78	335	269	F14	22	/	/	/	30	55	326	127
400	16	102	380	302	F14	22	/	/	/	36	55	370	140
450	18	114	410	328	F14	22	/	/	/	36	55	422	160
500	20	127	440	358	F16	26	/	/	/	40	65	470	178
550	22	154	475	406	F16	26	/	/	/	50	65	522	195
600	24	154	495	438	F16	26	/	/	/	50	65	566	215

Manual actuation

The selection of actuators given below typically applies to butterfly valves handling liquid fluids at the maximum flow velocities shown.

For valves handling non-lubricating fluids (gas), a max. flow velocity of 50 m/s applies.

Higher flow velocities and further actuator/valve combinations are possible, depending on the operating conditions and hydraulic characteristics. Please contact us.

Levers S - SR

Lever S <ul style="list-style-type: none"> Can be locked in end positions 	DN	NPS	Max. velocity	Levers S + SR with all fluids		
				l2	h2	Weight ⁴⁾
Lever SR <ul style="list-style-type: none"> Can be locked in 9 positions 			[m/s]	[mm]	[mm]	[kg]
	32	1¼	4,0	180	164	0,5
	40	1½	4,0	180	160	0,5
	50	2	4,0	180	170	0,5
	32	1¼	4,0	260	184	0,6
	40	1½	4,0	260	180	0,6
	50	2	4,0	260	190	0,6
	65	2½	4,0	260	205	0,6
	80	3	4,0	260	210	0,6
	100	4	4,0	330	235	0,7
	125	5	4,0	330	250	0,7
150	6	4,0	330	270	0,7	

Lever SP

Lever SP <ul style="list-style-type: none"> Can be locked in all positions 	DN	NPS	Max. velocity	Lever SP with all fluids		
				l2	h2	Weight ⁴⁾
			[m/s]	[mm]	[mm]	[kg]
	32	1¼	4,0	260	209	0,7
	40	1½	4,0	260	205	0,7
	50	2	4,0	260	210	0,7
	65	2½	4,0	260	236	0,7
	80	3	4,0	260	242	0,7
	100	4	4,0	330	263	1,4
	125	5	4,0	330	277	1,4
	150	6	4,0	330	294	1,4

⁴⁾ The weights given refer to the actuating element.

Levers CR - CM

	DN	NPS	Max. velocity [m/s]	Levers CR - CM				
				l1	d1	l2	h5	Weight ⁴⁾
				[mm]	[mm]	[mm]	[mm]	[kg]
	32	1¼	4,0	33	103	CR165	182	0,8
	40	1½	4,0	33	110	CR165	178	0,8
	50	2	4,0	43	122	CR165	188	0,8
	65	2½	4,0	46	139	CR165	203	0,8
	80	3	4,0	46	145	CR165	208	0,8
	100	4	4,0	52	152	CR230	236	1,2
	125	5	4,0	56	185	CR300	264	1,7
	150	6	4,0	56	210	CR300	284	1,7
	200	8	4,0	60	346	CR510 ⁵⁾	331	3,1

⁵⁾ High actuating torque, manual gearbox recommended

Manual gearbox MR

With lubricating fluid											
	DN	NPS	Max. velocity	Actuator	A	B	C	D	E	h2	Weight
			[m/s]		[mm]	[mm]	[mm]	[mm]	[mm]	[mm]	[kg]
	32	1¼	4,0	MR25	62	184	66	64	225	260	7
	40	1½	4,0	MR25	62	184	66	64	225	256	7
	50	2	4,0	MR25	62	184	66	64	225	266	7
	65	2½	4,0	MR25	62	184	66	64	225	281	7
	80	3	4,0	MR25	62	184	66	64	225	286	7
	100	4	4,0	MR25	62	184	66	64	225	301	7
	125	5	4,0	MR25	62	184	66	64	225	316	7
	150	6	4,0	MR25	62	184	66	64	225	336	7
	200	8	4,0	MR25	62	184	66	64	225	369	7
	250	10	4,0	MR50	74	184	77	76	225	428	10
	300	12	4,0	MR100	86	233	88	88	350	543	15
	350	14	4,0	MR100	86	233	88	88	350	572	15
	400	16	3,0	MR200	120	270	108	117	350	628	24
	450	18	3,0	MR200	120	270	108	117	350	658	24
	500	20	3,0	MR200	120	270	108	117	350	688	24
	550	22	3,0	MR400	229	332	115	125	350	775	58
600	24	3,0	MR400	229	332	115	125	350	795	58	

With non-lubricating fluid											
	DN	NPS	Max. velocity	Actuator	A	B	C	D	E	h2	Weight
			[m/s]		[mm]	[mm]	[mm]	[mm]	[mm]	[mm]	[kg]
	40	1½	*	MR25	62	184	66	64	225	260	7
	40	1½	*	MR25	62	184	66	64	225	256	7
	50	2	*	MR25	62	184	66	64	225	266	7
	65	2½	*	MR25	62	184	66	64	225	282	7
	80	3	*	MR25	62	184	66	64	225	286	7
	100	4	*	MR25	62	184	66	64	225	301	7
	125	5	*	MR25	62	184	66	64	225	316	7
	150	6	*	MR25	62	184	66	64	225	336	7
	200	8	*	MR50	74	184	77	76	225	381	10
	250	10	*	MR50	74	184	77	76	225	428	10
	300	12	*	MR100	86	233	88	88	350	543	15
	350	14	*	MR200	120	270	108	117	350	583	24
	400	16	*	MR200	120	270	108	117	350	628	24
	450	18	*	MR400	229	332	115	125	350	710	58
	500	20	*	MR400	229	332	115	125	350	740	58
	550	22	*	MR400	229	332	115	125	350	775	58
600	24	*	MR400	229	332	115	125	350	795	58	

*:Max. velocity with non-lubricating fluid (gas): 50 [m/s]

Variants

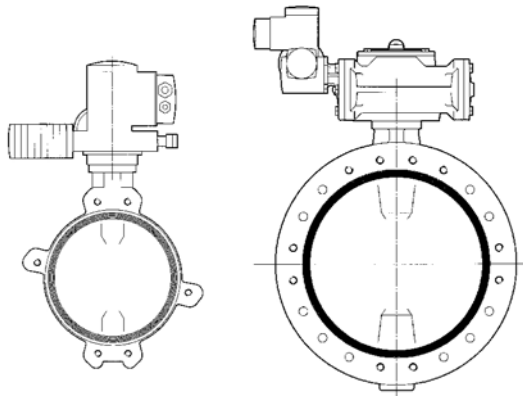

ACTELEC

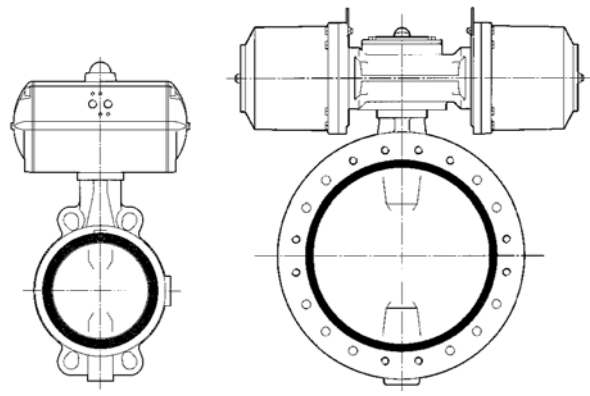

ACTAIR / DYNACTAIR

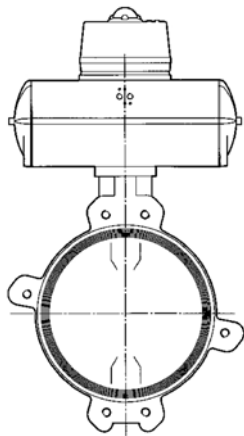

**ACTAIR +
AMTRONIC / SMARTRONIC**

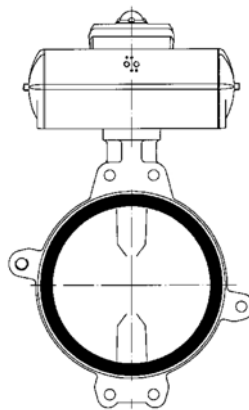

**ACTAIR +
AMTROBOX**

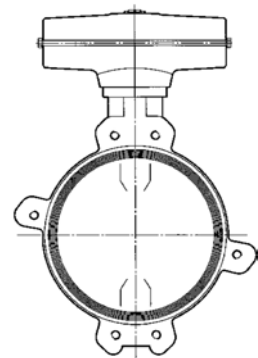

ACTO

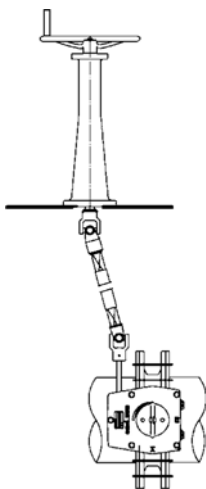

Deck stand

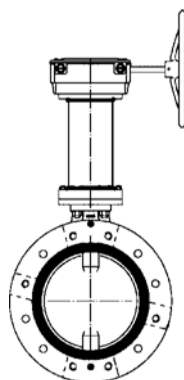

Extension

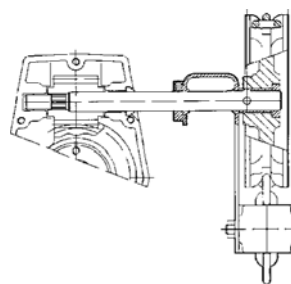

Chain wheel

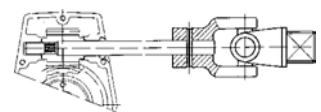

Cardan joint

Notes on installation

Connections

The valves can be installed between the following line connections (other line connections on request):

- EN 1092 PN 16, 20 and 25
- ASME B16.1 Cl.125 and B16.5 Cl.150
- ASME B16.47 Cl.150 Series A
- MSS SP 44 Cl.150
- AWWA C207 Cl. E
- AS 2129 Table E
- BS 10 Table E
- JIS B2220, B2238 and B2239 16K and 20K

Semi-lug body - T2

DN	NPS	EN 1092			ASME		MSS SP44 Cl. 150	JIS B2220, B2238, B2239		AWWA C207 Cl. E	BS10 Table E	AS2129 Table E
		PN 16	PN 20	PN 25	B16.1 Cl. 125	B16.1 Cl. 150		16K	20K			
32	1¼	✓	✓	✓	✓	✓	•	✓	✓	•	✓	✓
40	1½	✓	✓	✓	✓	✓	•	✓	✓	•	✓	✓
50	2	✓	✓	✓	✓	✓	•	✓■	✓■	•	✓	✓
65	2½	✓	✓	✓■	✓	✓	•	✓■	✓■	•	✓	✓
80	3	✓	✓	✓	✓	✓	•	✓	✓	•	✓■	✓■
100	4	✓	✓	✓	✓	✓	•	✓	✓	✓	✓■	✓■
125	5	✓	✓	✓	✓	✓	•	✓	✓	✓	✓	✓
150	6	✓	✓	✓	✓	✓	•	✓■	✓■	✓	✓	✓
200	8	✓	✓	✓▲	✓	✓	•	✓▲	✓▲	✓	✓	✓
250	10	✓	✓	✓	✓	✓	•	✓	✓	✓	✓	✓
300	12	✓	✓	✓	✓	✓	✓	✓	✓	✓	✓	✓
350	14	✓	✓	✓	✓	✓	✓	✓	✓	✓	✓	✓
400	16	✓	✓	✓	✓	✓	✓	✓	✓	✓	✓	✓
450	18	✓	✓	✓	✓	✓	✓	✓	✓	✓	✓	✓
500	20	✓	✓	✓	✓	✓	✓	✓	✓	✓	✓	✓
550	22	•	✓	•	•	•	✓	✓	✓	✓	✓	✓
600	24	✓	✓	✓	✓	✓	✓	✓	✓	✓	✓	✓

Full-lug body with flat faces -T3

DN	NPS	EN 1092			ASME	MSS SP44 Cl.150	MSS SP44 Cl.150	JIS B2220, B2238, B2239		AWWA C207 Cl. E UNC (94)	BS10 Table E UNC	AS2129 Table E UNC
		PN 16	PN 20	PN 25	B16.5 Cl. 150		16K	20K				
32	1¼	✓	✓	✓	✓	•	•	✓	✓	•	✓	✓
40	1½	✓	✓	✓	✓	•	•	✓	✓	•	✓	✓
50	2	✓	✓	✓	✓	•	•	♦	♦	•	✓	✓
65	2½	✓	✓	✓	✓	•	•	✓	✓	•	✓	✓
80	3	✓	✓	✓	✓	•	•	✓	✓	•	✓	✓
100	4	✓	✓	✓	✓	•	•	✓	✓	✓	✓	✓
125	5	✓	✓	✓	✓	•	•	✓	✓	✓	✓	✓
150	6	✓	✓	✓	✓	•	•	♦	♦	✓	✓	✓
200	8	✓	✓	✓	✓	•	•	✓	✓	✓	✓	✓
250	10	✓	✓	✓	✓	•	•	✓	✓	✓	✓	✓
300	12	✓	✓	✓	✓	✓	•	✓	✓	✓	✓	✓
350	14	✓	✓	✓	✓	✓	•	✓	✓	✓	✓	✓
400	16	✓	✓	✓	✓	✓	•	✓	✓	✓	♦	♦
450	18	✓	✓	✓	✓	✓	✓	✓	✓	✓	✓	✓
500	20	✓	✓	✓	✓	✓	✓	✓	✓	✓	♦	♦
600	24	✓	✓	✓	✓	✓	✓	✓	✓	✓	♦	♦

Full-lug body with raised faces -T4

DN	NPS	EN 1092			ASME		MSS SP44 Cl. 150	JIS B2220, B2238, B2239		AWWA C207 Cl. E	BS10 Table E	AS2129 Table E
		PN 16	PN 20	PN 25	B16.1 Cl. 125	B16.5 Cl. 150		16K	20K			
32	1¼	✓	✓	✓	✓	✓	•	✓	✓	•	✓	✓
40	1½	✓	✓	✓	✓	✓	•	✓	✓	•	✓	✓
50	2	✓	✓	✓	✓	✓	•	♦	♦	•	✓	✓
65	2½	✓	✓	♦	✓	✓	•	♦	♦	•	✓	✓
80	3	✓	✓	✓	✓	✓	•	✓	✓	•	✓	✓
100	4	✓	✓	✓	✓	✓	•	✓	✓	✓	✓	✓
125	5	✓	✓	♦	✓	✓	•	♦	♦	✓	✓	✓
150	6	✓	✓	♦	✓	✓	•	♦	♦	✓	✓	✓
200	8	✓	✓	♦	✓	✓	•	♦	♦	✓	✓	✓
250	10	✓	✓	♦	✓	✓	•	♦	♦	✓	✓	✓
300	12	✓	✓	✓	✓	✓	✓	✓	✓	✓	✓	✓
350	14	✓	✓	✓	✓	✓	✓	✓	✓	✓	✓	✓
400	16	✓	✓	✓	✓	✓	✓	✓	✓	✓	♦	♦
450	18	✓	✓	✓	✓	✓	✓	✓	✓	✓	✓	✓
500	20	✓	✓	✓	✓	✓	✓	✓	✓	✓	♦	♦
550	22	•	✓	•	•	•	✓	✓	✓	✓	♦	♦
600	24	✓	✓	✓	✓	✓	✓	✓	✓	✓	♦	♦

Flanged body with flat faces -T5

DN	NPS	EN 1092			ASME		MSS SP44 Cl. 150	JIS B2220, B2238, B2239		AWWA C207 Cl. E	BS10 Table E	AS2129 Table E
		PN 16	PN 20	PN 25	B16.1 Cl. 125	B16.1 Cl. 150		16K	20K			
200	8	✓	✓	✓■	✓	✓	•	✓	✓	✓	✓	✓
250	10	✓	✓	✓■	✓	✓	•	✓	✓	✓	✓	✓
300	12	✓	✓	✓	✓	✓	✓	✓	✓	✓	✓	✓
350	14	✓	✓	✓■	✓	✓	✓	✓	✓	✓	✓	✓
400	16	✓	✓	✓■	✓	✓	✓	✓	✓	✓	✓	✓
450	18	✓	✓	♦	✓	✓	✓	♦	♦	✓	✓	✓
500	20	✓	✓	✓	✓	✓	✓	✓	✓	✓	✓	✓
550	22	•	✓	•	•	•	✓	♦	♦	✓	✓	✓
600	24	✓	✓	✓	✓	✓	✓	✓	✓	✓	✓	✓

Key to the symbols

Symbol	Description	Symbol	Description
✓	Installation possible	•	Non-standardised connection
■	Downstream dismantling not possible	♦	Installation not possible

Dead-end service and downstream dismantling

Downstream dismantling

For downstream dismantling,
successively loosen diagonally opposed tie rods.

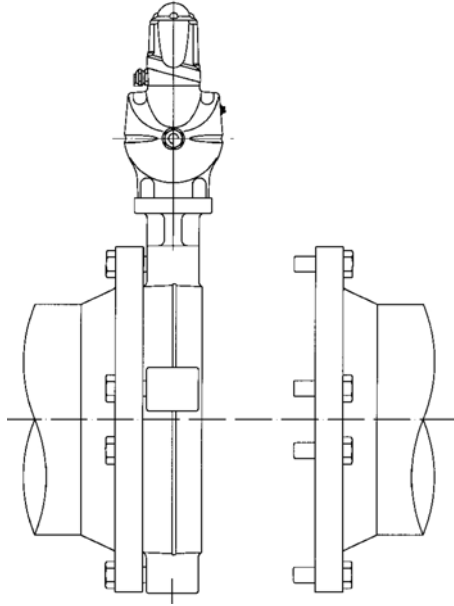

Dead-end service

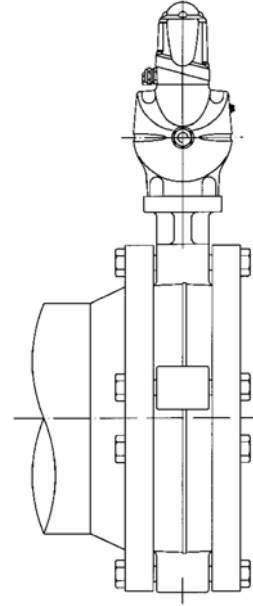

Bolting and weights

Semi-lug body - T2

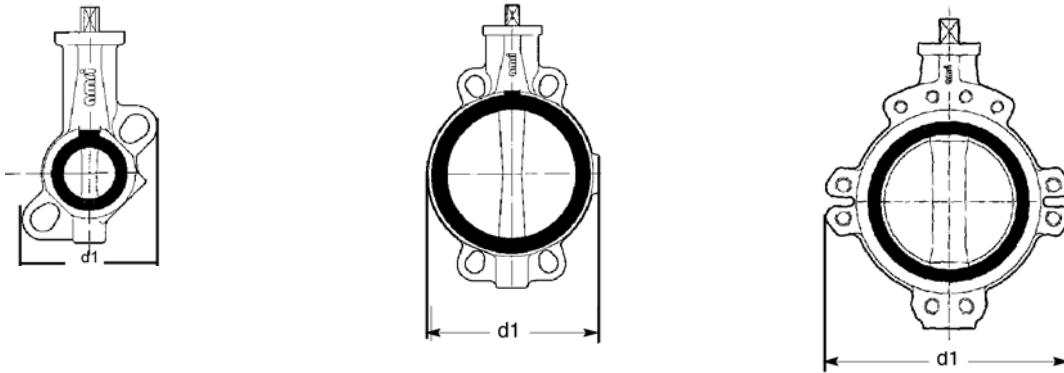

The drawings do not indicate the exact product design
(number of tapped lugs/tapped holes/through-holes)

N.B.: Bolting is not included in our standard scope of supply.

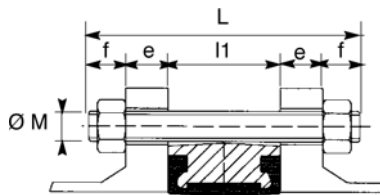

Length of tie rod $L = l1 + 2e + 2f$

- L: minimum length of tie rods
- l1: face-to-face length of butterfly valve
- e: flange thickness (customer-specific)
- f: thickness of nut + standardised overhang of tie rod

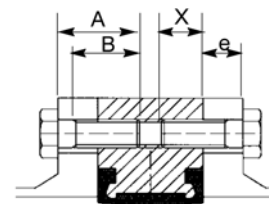

Bolt length at stem passage

$A = e + X$

- A: max. bolt length
- X: max. thread engagement depth
- e: flange thickness (customer-specific)
- B: min. thread length > A-e

Semi-lug body - T2

DN	NPS	I1	d1	EN 1092-1 PN 16					EN 1092-1 PN 25					Weight [kg]
				Ø M	Tie rod ⁶⁾		Bolt		Ø M	Tie rod ⁶⁾		Bolt		
					f	Qty	X	Qty ⁷⁾		f	Qty	X	Qty ⁷⁾	
32	1¼	33	103	M16	20	4	-	-	M16	20	4	-	-	1,2
40	1½	33	110	M16	20	4	-	-	M16	20	4	-	-	1,3
50	2	43	122	M16	20	4	-	-	M16	20	4	-	-	1,8
65	2½	46	139	M16	20	4/8	-	-	M16	20	4/8	-	-	2,3
80	3	46	145	M16	20	8	-	-	M16	20	8	-	-	3,2
100	4	52	152	M16	20	8	-	-	M20	24	8	-	-	4,5
125	5	56	185	M16	20	8	-	-	M24	29	8	-	-	6,7
150	6	56	210	M20	24	8	-	-	M24	29	8	-	-	7,5
200	8	60	346	M20	24	12	-	-	M24	29	12	-	-	14,0
250	10	68	413	M24	29	12	-	-	M27	32	12	-	-	20,0
300	12	78	520	M24	29	6	24	6	M27	32	10	27	6	48,0
350	14	78	539	M24	29	10	24	6	M30	35	10	30	6	60,0
400	16	102	604	M27	32	10	27	6	M33	38	10	33	6	80,0
450	18	114	657	M27	32	14	27	6	M33	28	14	33	6	110,0
500	20	127	716	M30	35	12	30	8	M33	24	12	33	8	145,0
550	22	154	782	•	•	•	•	•	•	•	•	•	•	•
600	24	154	836	M33	38	10	33	10	M36	42	10	36	10	220,0

DN	NPS	I1	d1	ASME B16.5 Class 150 ASME B16.1 Class 125 MSS SP 44 Class 150 ASME B16.47 Class 150 Series A 8)					JIS B2220, B2238, B2239 16K					Weight [kg]
				UNC	Tie rod ⁶⁾		Bolt		Ø M	Tie rod ⁶⁾		Bolt		
					f	Qty	X	Qty ⁷⁾		f	Qty	X	Qty ⁷⁾	
32	1¼	33	108	1/2"	17	4	-	-	M16	20	4	-	-	1,2
40	1½	33	108	1/2"	17	4	-	-	M16	20	4	-	-	1,3
50	2	43	118	5/8"	20	4	-	-	M16	20	8	-	-	1,8
65	2½	46	132	5/8"	20	4	-	-	M16	20	8	-	-	2,3
80	3	46	138	5/8"	20	4	-	-	M20	24	8	-	-	3,2
100	4	52	150	5/8"	20	8	-	-	M20	24	8	-	-	4,5
125	5	56	234	3/4"	24	8	-	-	M22	26	8	-	-	6,7
150	6	56	260	3/4"	24	8	-	-	M22	26	12	-	-	7,5
200	8	60	322	3/4"	24	8	-	-	M22	26	12	-	-	14,0
250	10	68	394	7/8"	29	12	-	-	M24	29	12	-	-	20,0
300	12	78	462	7/8"	29	12	24	6	M24	29	10	24	6	48,0
350	14	78	538	1"	32	6	27	6	M30x3	35	10	30	6	60,0
400	16	102	604	1"	32	10	27	6	M30x3	35	16	30	6	80,0
450	18	114	656	1" 1/8	35	10	30	6	M30x3	35	14	30	6	110,0
500	20	127	716	1" 1/8	35	12	30	8	M30x3	35	12	30	8	145,0
550	22	154	804	1" 1/4	38	12	32	8	M36x3	42	12	36	8	180,0
600	24	154	836	1" 1/4	38	10	32	10	M36x3	42	14	36	10	220,0

6) Quantity of nuts = Quantity of tie rods x 2

7) Quantity of bolts x 2

8) DN's concerned, see connection standards

Full-lug body with raised / flat faces - T3 / T4

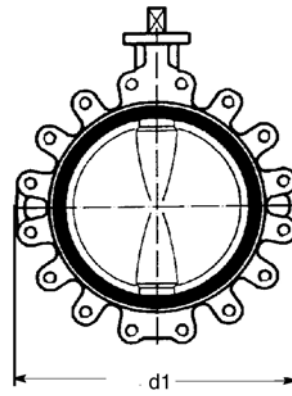
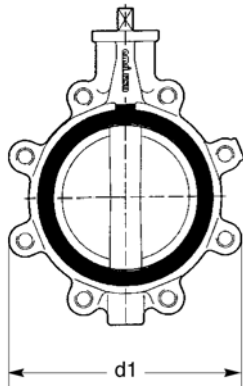

The drawings do not indicate the exact product design (number of tapped lugs).

N.B.: Bolting is not included in our standard scope of supply.

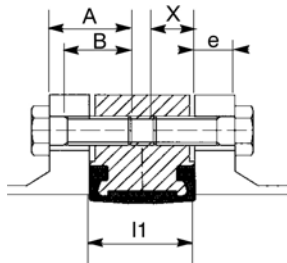

$$A = e + X$$

A: max. bolt length

X: max. thread engagement depth

e: flange thickness (customer-specific)

B: min. thread length > A-e

Full-lug body with raised / flat faces - T3 / T4

DN	NPS	I1	d1	EN 1092-1 PN 16			EN 1092-1 PN 25			ASME B16.5 Class 150 ASME B16.1 Class 125 MSS SP 44 Class 150 ASME B16.47 Class 150 Serie A 9)			JIS B2220, B2238, B2239 16K			Weight [kg]
				Ø M	Bolt		Ø M	Bolt		UNC	Bolt		Ø M	Bolt		
					X	Qty ¹⁰⁾		X	Qty ¹⁰⁾		X	Qty ¹⁰⁾		X	Qty ¹⁰⁾	
32	1¼	33	101	M16	14	4	M16	14	4	1/2"	14	4	M16	14	4	2,0
40	1½	33	106	M16	14	4	M16	14	4	1/2"	14	4	M16	14	4	2,0
50	2	43	117	M16	18	4	M16	18	4	5/8"	18	4	•	•	•	2,5
65	2½	46	132	M16	20	4/8	•	•	•	5/8"	20	4	•	•	•	3,0
80	3	46	139	M16	20	8	M16	20	8	5/8"	20	4	M20	20	8	4,0
100	4	52	160	M16	22	8	M20	24	8	5/8"	22	8	M20	24	8	5,5
125	5	56	234	M16	22	8	•	•	•	3/4"	23	8	•	•	•	9,0
150	6	56	257	M20	26	8	•	•	•	3/4"	26	8	•	•	•	11,0
200	8	60	310	M20	26	12	•	•	•	3/4"	26	8	•	•	•	24,0
250	10	68	394	M24	29	12	•	•	•	7/8"	28	12	•	•	•	39,0
300	12	78	462	M24	30	12	M27	34	16	7/8"	28	12	M24	30	16	46,0
350	14	78	527	M24	30	16	M30	24	16	1"	30	12	M30x3	34	16	62,0
400	16	102	605	M27	34	16	M33	40	16	1"	34	16	M30x3	37	16	101,0
450	18	114	636	M27	34	20	M33	40	20	1 1/8"	37	16	M30x3	37	20	122,0
500	20	127	718	M30	37	20	M33	40	20	1 1/8"	37	20	M30x3	37	20	179,0
550	22	154	790	•	•	•	•	•	•	1 1/4"	39	20	M36x3	42	20	233,0
600	24	154	835	M33	42	20	M36	45	20	1 1/4"	42	20	M36x3	34	24	256,0

- Non-standardised connection

9) DN's concerned, see connection standards

10) Quantity of bolts x 2

Flanged body with flat faces -T5

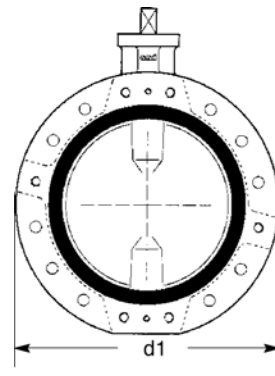
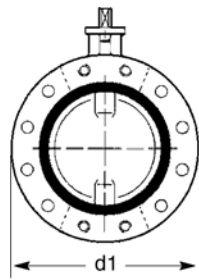

The drawings do not indicate the exact product design (number of tapped holes/plain holes)

N.B.: Bolting is not included in our standard scope of supply.

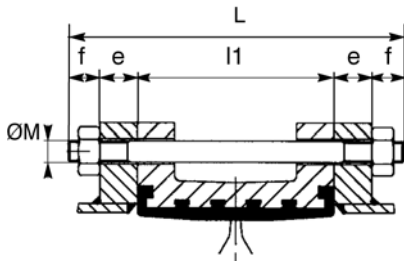

Length of tie rod $L = l1 + 2e + 2f$

L: minimum length of tie rods

l1: face-to-face length of butterfly valve

e: flange thickness (customer-specific)

f: thickness of nut + standardised overhang of tie rod

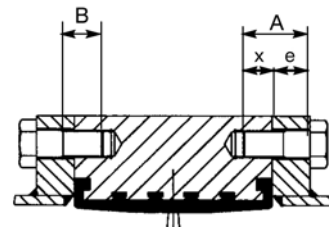

Bolt length at stem passage

$A = e + X$

A: max. bolt length

X: max. thread engagement depth

e: flange thickness (customer-specific)

B: min. thread length > A-e

Flanged body with flat faces -T5

DN	NPS	l1	d1	EN 1092-1 PN 16					EN 1092-1 PN 25					Weight [kg]
				Ø M	Tie rod ¹¹⁾		Bolt		Ø M	Tie rod ¹¹⁾		Bolt		
					f	Qty	X	Qty ¹²⁾		f	Qty	X	Qty ¹²⁾	
200	8	60	343	M20	24	8	16	4	M24	29	12	-	-	23
250	10	68	406	M24	29	8	24	4	M27	32	12	-	-	40
300	12	78	483	M24	29	6	24	6	M27	32	10	27	6	60
350	14	78	533	M24	29	10	24	6	M30	35	16	-	-	80
400	16	102	597	M27	32	10	27	6	M33	38	16	-	-	105
450	18	114	640	M27	32	14	27	6	M33	38	14	33	6	130
500	20	127	715	M30	35	12	30	8	M33	38	12	33	8	180
550	22	154	749	•	•	•	•	•	•	•	•	•	•	•
600	24	154	840	M33	38	10	33	10	M36	42	10	36	10	260

DN	NPS	l1	d1	ASME B16.5 Class 150 ASME B16.1 Class 125 MSS SP 44 Class 150 ASME B16.47 Class 150 Series A 13)					JIS B2220, B2238, B2239 16K					Weight [kg]
				UNC	Tie rod ¹¹⁾		Bolt		Ø M	Tie rod ¹¹⁾		Bolt		
					f	Qty	X	Qty ¹²⁾		f	Qty	X	Qty ¹²⁾	
200	8	60	343	3/4"	24	4	20	4	M22	26	8	22	4	23
250	10	68	406	7/8"	29	8	24	4	M24	29	8	24	4	40
300	12	78	483	7/8"	29	6	24	6	M24	29	10	24	6	60
350	14	78	533	1"	32	6	27	6	M30x3	35	10	30	6	80
400	16	102	597	1"	32	10	27	6	M30x3	35	10	30	6	105
450	18	114	640	1 1/8"	32	10	30	6	•	•	•	•	•	130
500	20	127	715	1 1/8"	35	12	30	8	M30x3	35	12	30	8	180
550	22	154	749	1 1/4"	35	12	32	8	•	•	•	•	•	230
600	24	154	840	1 1/4"	38	10	32	10	M30x3	42	14	36	10	260

11) Quantity of nuts = Quantity of tie rods x 2

12) Quantity of bolts x 2

13) DN's concerned, see connection standards

Flange dimensions

The valves can be installed between all commercial mating flanges and line connections without requiring any flange gaskets.

The elastomer liner alone provides a tight seal at the flange connections.

Please verify that the connection meets the requirements given below.

The flange dimensions indicated in the table apply to all body types.

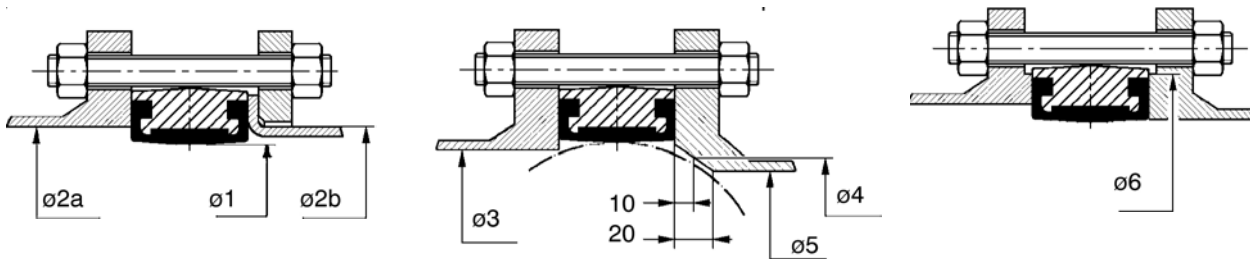

Ø2a and Ø3: flange face diameter

Ø2b: pipe OD with loose plate flange to DIN 2642 and NFE 29-251

Dimensions

DN	NPS	Optimum Ø	Max. permissible Ø		Min. permissible Ø on flange face	Min. Ø at a distance of 10 mm from the flange face	Min. Ø at a distance of 20 mm from the flange face	Min. permissible Ø of flange shoulder of flanges with raised faces
			Ø1	Ø2a				
40	1¼	32	44	43	-	-	-	64
40	1½	40	50	49	33	-	-	73
50	2	50	63	61	38	-	-	89
65	2½	65	78	77	55	-	-	104
80	3	80	92	89	74	53	-	124
100	4	100	117	115	92	77	48	147
125	5	125	145	140	117	107	88	177
150	6	150	172	169	143	137	123	202
200	8	195	223	220	191	183	173	251
250	10	245	278	273	241	234	226	305
300	12	295	329	324	290	284	276	358
350	14	330	361	356	326	321	314	399
400	16	380	412	407	370	366	358	452
450	18	430	463	457	422	416	409	505
500	20	480	515	508	470	464	457	558
550	22	540	568	561	522	516	509	625
600	24	580	617	610	566	560	554	664

Coated flange

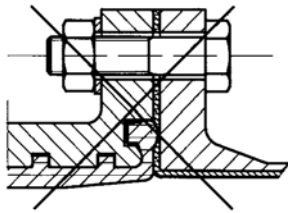

Flange with rubber coating

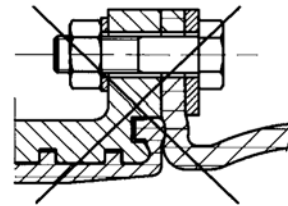

Expansion bellows

N.B.: Direct installation between rubber-coated flanges or with expansion bellows is not permitted. Contact KSB.

Installation between flanges made of polyethylene

- Installation between flanges with flat faces is permitted.
- Installation between flanges with grooved faces is not permitted.



KSB S.A.S.
4, allée des Barbanniers • 92635 Gennevilliers Cedex (France)
Tél. +33 1 41 47 75 00 • Fax +33 1 41 47 75 10 • www.ksb.com

12.05.2015

8446.1/11-EN