



INSTALLATION MAINTENANCE

- General over view
 - Tooling
 - Installation
 - Adjustment of opening or closing adjustable end stops
 - Actuator dysassembly
 - Actuator re-assembly
 - Trouble shooting
 - Kits sheets
- | | |
|------------|-------------------|
| ACTAIR 1,5 | Ref. 8516.8001-90 |
| ACTAIR 3 | Ref. 8516.8003-90 |
| ACTAIR 6 | Ref. 8516.8006-90 |
| ACTAIR 12 | Ref. 8516.8012-90 |
| ACTAIR 25 | Ref. 8519.8025-90 |
| ACTAIR 50 | Ref. 8519.8050-90 |

42 057 219

KSB is approved ISO 9001

RECOMMENDED TOOLS (not supplied)

- Pneumatic screwing machine
- Open ended spanner 16
- Allen key 4 and 5
- Clamp spring retaining ring

CONSUMABLES

- Grease EPEXELF MO2 (Elf) or RETINAX AM (Shell) or equivalent

INSTALLATION
BEFORE ANY ACTION

- Index the mounting position of the actuator onto the valve (Position N or M)
- Index the position of the pointer 629 on the pinion

ADAPTATION

The adaptation onto the valves is achieved either directly or through adaptor parts :

- interchangeable inserts manufactured to the size and the shape of the different valve shafts
- adaptor flanges for the coupling.

ACTUATOR POSITION ONTO THE VALVE

If the open or closed position are not known it is then necessary to apply air pressure in order to obtain clockwise operation : then, the actuator is in a closed position.

The actuator can be positioned in four positions, at 90° intervals.

Standard arrangement is the N position 1

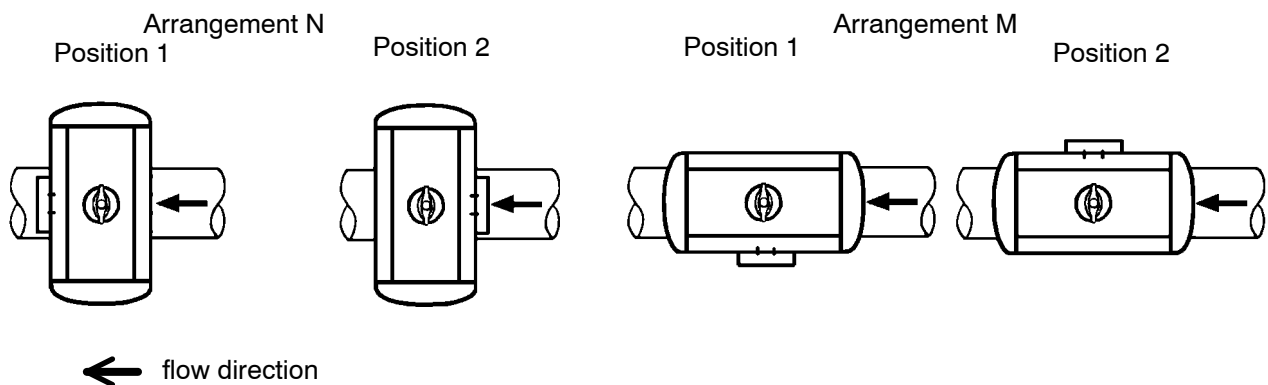

The arrangement position can be modified on site by following the procedure below while adhering to the specific assembly operations in accordance with the maintenance procedure.

TRANSFORMATION Arrangement N ↔ Arrangement M

- Disconnect the actuator from the valve,
- Remove the pointer 629,
- Remove the ball 486 out of the groove using a screwdriver, pin punch, . . .
- Insert the ball 486 in the perpendicular groove,
- Mount the pointer at 90° in initial position,
- Remove the insert of the pinion, make 90° turn and re-insert in the pinion,
- Reconnect the actuator onto the valve at 90° of the initial position.

ADJUSTMENT OF STANDARD CLOSING ADJUSTABLE END STOPS ($\pm 2^\circ$)

Adjustable end stops are adjusted in the factory.

This is of utmost importance for the perfect tightness of the valve.

After any intervention on the actuator, the correct adjustment of the adjustable end stops must be verified.

If need be, this adjustment will be modified as per the following procedure :

Adjustment to carry out on the unit valve + actuator attached

- Disconnect the air supply,
- Unlock the nuts 920,
- Unscrew one of the two adjustable end stops 909 of several turns,
- Adjust the other adjustable end stop 909, by pressurizing the internal chamber (between the 2 pistons) and verifying the required position then lock the screw 909 with nut 920,
- Disconnect the air supply, adjust the first adjustable end stops 909 until contact is made with the piston 595, then lock it with nut 920. In the same way, pinion 877 must not be put in rotation.

WARNING : During the adjustment operations, the O-rings 412.4 should not be damaged.

CASE OF ACTAIR 1.5 to 50 WITH ADJUSTMENT OF OPENING ADJUSTABLE END STOPS

Follow the same procedure of adjusting.

An **O** is ungraved on the driving shaft of pinion 877 of an actuator with **O**pening adjustable end stops.



SPECIFIC CASE : ACTUATOR EQUIPPED WITH A DECLUTCHABLE MANUAL OVERRIDE

Adjustment to carry out on the unit valve + declutchable manual override + actuator attached

Under pressure, in automatic operation, the stop in position of the unit must be made on pneumatic actuator adjustable end stops.

Mandatory adjustment chronological operation to respect :

- Disconnect the air supply,
- Unscrew of several turns (4 to 5 turns) the two adjustable end stops of the declutchable manual override
- Unlock the nuts 920,
- Unscrew one of the two adjustable end stops 909 of several turns,
- Adjust the other adjustable end stop 909, by pressurizing the internal chamber (between the 2 pistons) and verifying the required position, then lock the screw 909 with nut 920,
- Disconnect the air supply, adjust the first adjustable end stops 909 until contact is made with the piston 595, then lock it with nut 920. In the same way, pinion 877 must not be put in rotation.
- Connect the air supply, screw the closing adjustable end stops of the manual override until contact with the wheel, then unscrew 1/2 turn and lock its counter-nut
- Put the unit in opening position and let the pressure in the actuator
- Screw the opening adjustable end stops of the manual override until contact with the wheel, then unscrew 1/2 turn and lock its counter-nut
- Check the correct operation of the unit

ACTUATOR DYSASSEMBLY

- Identify both the pointer and the mounting position of the actuator onto the valve.
- Disconnect the air supply
- Remove the actuator and the accessories from the valve and place it on a work bench
- Disconnect all accessories of the actuator
- If the actuator has a pointer 629 and a plug 916, remove them
- Remove cylinder heads 163
- Extract cylinder head gaskets 410
- Remove nuts 920, washers 554 and O-rings 412.4 of the cylinders heads 163

Before the next sequence :

Note the angular position P1 of pinion 877 when pistons 595 are not in movement

In the same way, note P2 position of the piston teeth 595 compared to the pinion 877.

Two functions are possible in accordance with figures below.

Clockwise closure version / Adjusting screws at the closed position

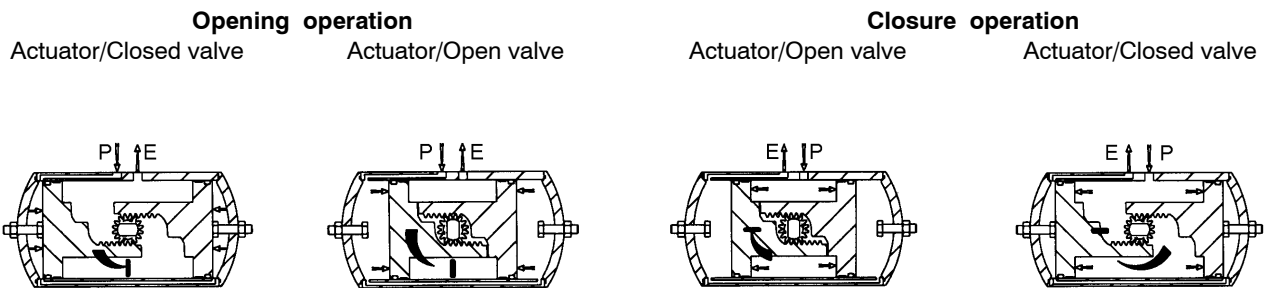

Clockwise closure version / Adjusting screws at the open position

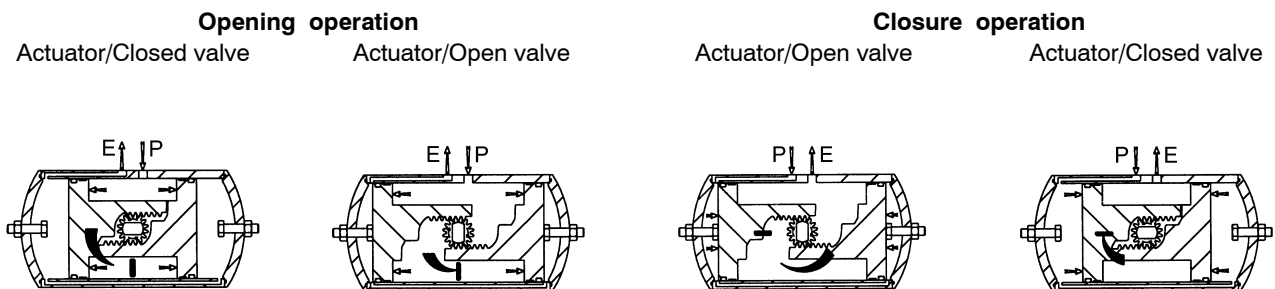

- Extract pistons 595 out of housing 103 operating the driving square of pinion 877 using a wrench size 16
- Remove piston guide 81-68, piston bearing 593 and O-rings 412.3 of the pistons 595
- Remove spring retaining ring 932, thrust washer 314 and friction washer 55-2
- Extract pinion 877
- Extract bearings 300.1 and 300.2, O-rings 412.1 and 412.2 of the pinion 877

ACTUATOR RE-ASSEMBLY

PREPARATION OF PARTS

All constitutive parts of the spare kits must be used.

O-rings, bearings and piston guide must be lubricated with grease defined in the paragraph : consummables.

WARNING : DO NOT GREASE THE GROOVE OF THE SPRING RETAINING RING

- Fit O-rings 410 and 412.4,
washers 554
and nuts 920
on the cylinder heads



The standard position of the adjustable end stop is as below :

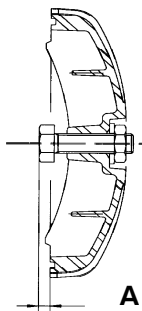

A Position dimension
of the adjustable end stop 909

ACTUATOR	A (mm)
ACTAIR 1,5	6,5
ACTAIR 3	15,1
ACTAIR 6	11,5
ACTAIR 12	4,9
ACTAIR 25	17,3
ACTAIR 50	8,2

Fit O-ring 412.2, lower bearing 300.2, upper bearing 300.1 and O-ring 412.1 on the pinion 877.
Grease O-rings, bearings and pinion teeth.



Fit O-rings 412.3, piston guide 81.68 and piston bearings 593 on the piston 595.
Grease the piston teeth

RE-ASSEMBLY

Strictly follow the order of operations

- Grease the cylinder of the housing 103 using a brush or any other appropriate method
- Fit the pinion sub-unit



- Put in place the lubricated friction washer 55-2, the thrust washer 314 and the spring retaining ring 932.
- WARNING : THE SPRING RETAINING RING MUST BE FITTED FLAT FACE TOWARDS THE UPPER SQUARE OF THE PINION AND SHOULD NOT BE TOO OPENED SINCE IT MADE BE DEFORMED.**

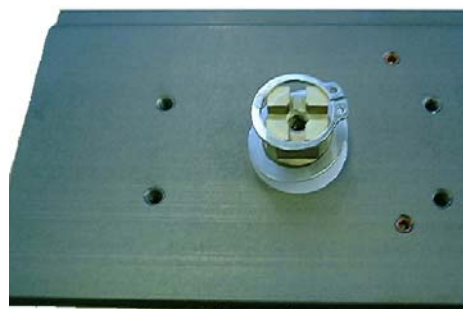
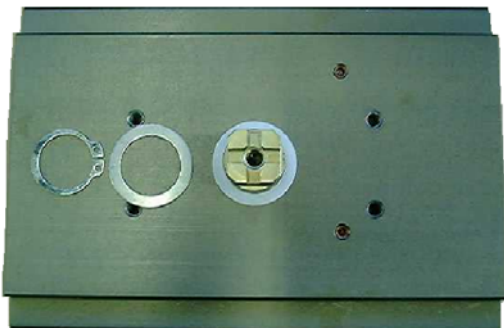

- Orientate the pinion 877 using size 16 spanner in position P1 already noted during the disassembly.
In case of problem, refer to drawing there after :

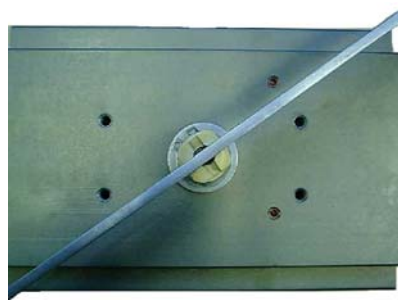

- Insert piston sub-units in the housing 103 in the same position P2, already noted during the disassembly.
In case of problem, refer to drawings there after :

Position of pinion teeth 877 and pistons 595 must be as follows :



Drawn adjustable end stops in closing position

- Drive the pistons in the housing operating the pinion 877 with size 16 spanner, and pushing manually on the pistons.

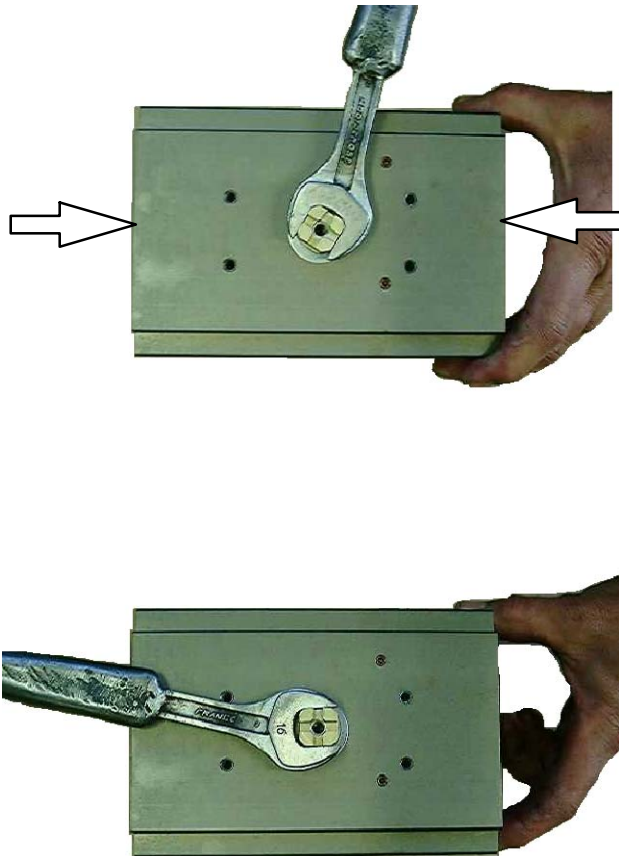

- Check that the 2 pistons 595 are equally inserted in housing 103 and that the pinion square 877 shows the correct position on opened - closed position.
Using a spanner, check the correct operation of the assembly closed - opened position
- Refit the sub-unit cylinder head on the housing 103 screwing alternatively the 4 screws
- Check the good operation of the actuator (stroke, tightness)

CONNECTION ONTO THE VALVE

- Re-mount the pointer 629 and/or accessories on the actuator in its initial position.
- Connect the actuator on the valve in its initial position,
- Check the good operation of the unit valve- pneumatic actuator - accessories.
- If necessary, adjust adjustable end stops : see § adjustment of standard closing adjustable end stops.

TROUBLE SHOOTING

	At cylinder heads 163	
	Axial at pinion 877	External leakages
	At plugs 903	
	Non operation	
	Incomplete operation or on stroke	
	Irregular operation	
	Reverse operation	
	Disfonctionning of the apparatus	
	Reverse or incorrecte indication	
	Not possible connection, valve side	
	Not possible connection, accessories side	
	Damaged O-rings 412.1 and 410	Change O-rings 412.1 and 410
	Damaged O-rings 412.3 and 412.2	Change O-Rings 412.3 and 412.2
	Damaged plugs 903 and O-rings 412.6	Change plug 903 and O-ring 412.6
	Absence or insufficient pressure	Check solenoïd, restrictors, pressure, connections
	Blocked valve	Check the valve and/or the interface with the pipe
	Internal leakages	Change O-rings 412.4
	External leakage	See external leakages
	Rupture of internal components	Consult the manufacturer for technical advices
	Wrong applicabilities	Consult technical leaflet Nr 8515 Consult technical leaflet of the valve
	Declutchable manual override	Disconnect the air supply Clutch the manual override
	If distribution AMTRONIC : possible presence of screws 904	Disconnect AMTRONIC Remove screws 904
	Wrong adjustment of adjustable end stops	Refer to § adjustment of adjustable end stops
	Wrong adjustment of positioner function AMTRONIC	Consult technical leaflet Nr. 2316
	Overtorque of the valve	Contact the manufacturer
	Wrong interface	Check the driving and/or adapter flanges Consult technical leaflet ACTAIR Nr. 8515 or contact the manufacturer
	Air flow too low	Check solenoïd, restrictors, pressure, connexions and passage section of the air supply
	Closed actuator / Opened actuator or Closed actuator	Put valve and actuator in the same position
	Inverted pneumatic connections	Check the pneumatic connection
	Wrong definiton of the solenoïd	Check solenoïds definiton
	Wrong assembly of the actuator onto the actuator	Check arrangement positions on the ACTAIR technical leaflet Nr.8515
	Loss air pressure	Pressurize the equipment and keep it under pressure
	Internal or external leakages with flow control equipment + AMTRONIC or varying input signal	See external or internal leakages Check the O-ring of the mounting plate between ACTAIR and AMTRONIC
	Wrong adjustment of limit switches cams	Check the adjustment according to the technical leaflet AMTRONIC Nr. 2316
	Control and remote indication non compatible	Check accessories technical leaflet

KITS SHEETS

ACTAIR 1,5	Ref. 8516.8001-90
ACTAIR 3	Ref. 8516.8003-90
ACTAIR 6	Ref. 8516.8006-90
ACTAIR 12	Ref. 8516.8012-90
ACTAIR 25	Ref. 8519.8025-90
ACTAIR 50	Ref. 8519.8050-90

CODING CODIFICATION KODIERUNG	Temperature range Plage de température Temperatur	Specificities Spécificités Spezifikationen
42 095 623	-20 °C to • à • bis +80 °C	

Base plate version

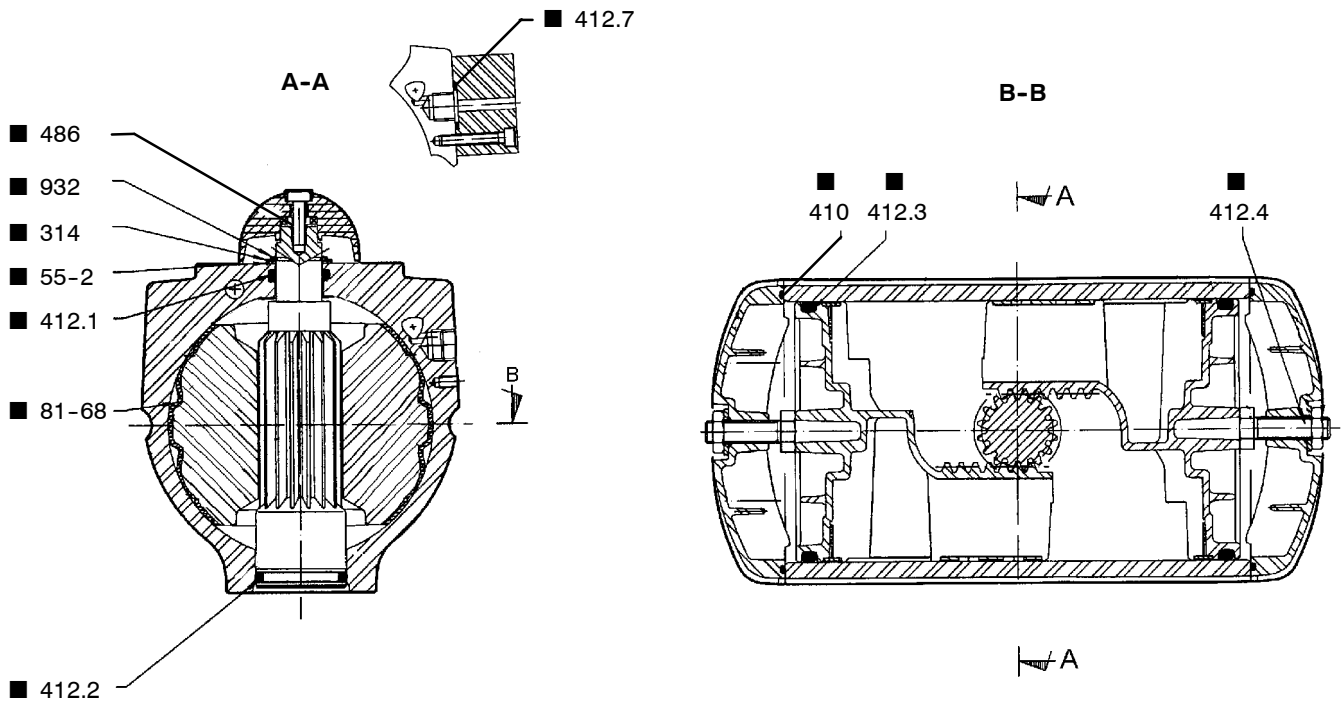

Item*	Qty	Designation	Désignation	Benennung	Materials / Matériaux Werkstoffe	Dimensions
314	■ 1	Thrust washer	Rondelle butée	Anschlagscheibe	Stainless steel	
410	■ 2	Cylinder head gasket	Joint de culasse	Zylinderdeckeldichtung	Nitril	
412.1	■ 2	O-ring	Joint torique	O-Ring	Nitril	Ø
412.2	■ 1	O-ring	Joint torique	O-Ring	Nitril	Ø
412.3	■ 2	Piston O-ring	Joint de piston	Kolbendichtung	Nitril	Ø
412.4	■ 2	O-ring	Joint torique	O-Ring	Nitril	Ø
412.7	■ 1	O-ring	Joint torique	O-Ring	Nitril	Ø
55-2	■ 1	Friction washer	Rondelle de frottement	Unterlegscheibe	Acetal	
81-68	■ 2	Piston guide	Patin	Gleitschuh	Acetal	
486	■ 2	Ball	Bille	Kugel	Stainless steel	
932	■ 1	Spring retaining ring	Circlips	Sicherungsring	Stainless steel	

CODING CODIFICATION KODIERUNG	Temperature range Plage de température Temperatur	Specificities Spécificités Spezifikationen
42 088 708	-20 °C to • à • bis +80 °C	* O-rings item 412.1 ; 412.2 ; 412.3: Nitril
42 088 863	-40 °C to • à • bis +80 °C	* O-rings item 412.1 ; 412.2 ; 412.3: Nitril low temperature
42 088 864	-20 °C to • à • bis +120 °C	* O-rings item 412.1 ; 412.2 ; 412.3: Viton

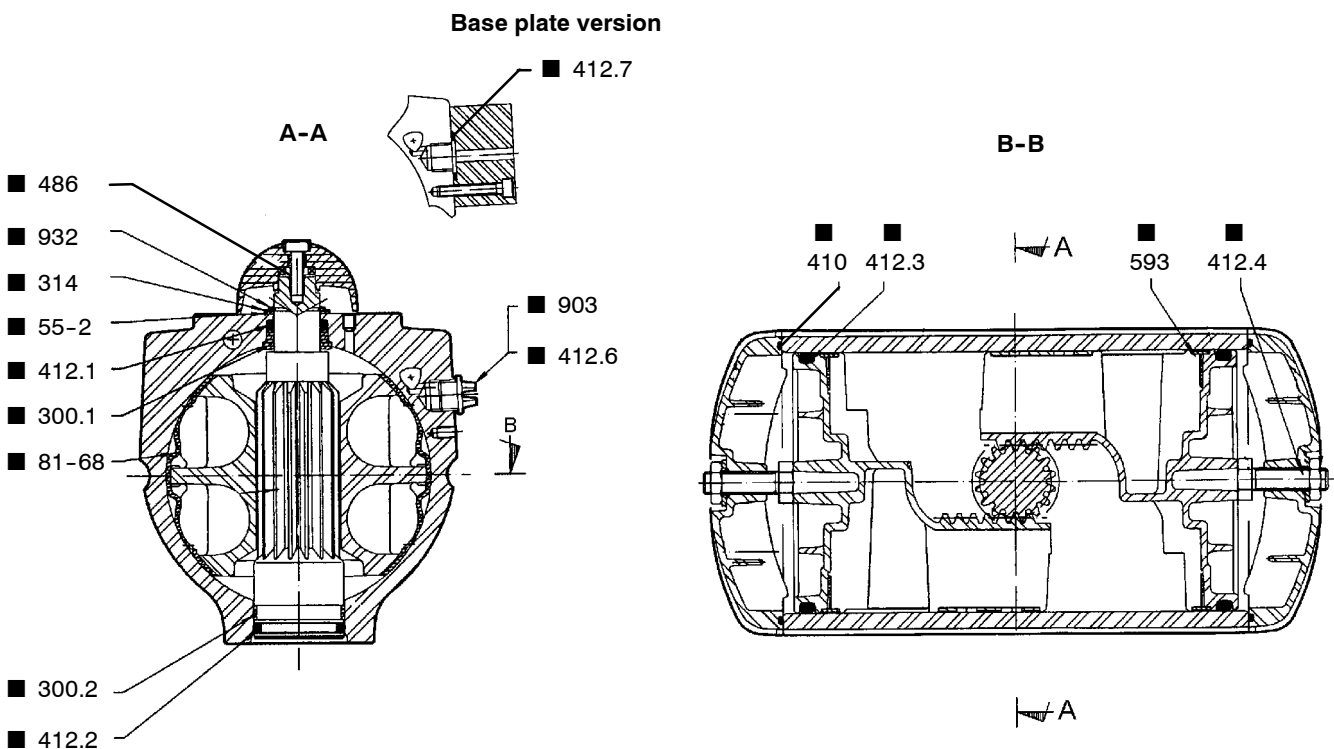

Item*	Qty	Designation	Désignation	Benennung	Materials / Matériaux Werkstoffe	Dimensions (mm)
300.1	1	Upper bearing	Palier supérieur	oberes Lager	Acetal	
300.2	1	Lower bearing	Palier inférieur	unteres Lager	Acetal	
314	1	Thrust washer	Rondelle butée	Anschlagscheibe	Stainless steel	
410	2	Cylinder head gasket	Joint de culasse	Zylinderdeckeldichtung	Nitril	
412.1*	1	O-ring	Joint torique	O-Ring	*	Ø 19,80 x 3,6
412.2*	1	O-ring	Joint torique	O-Ring	*	Ø 23,00 x 3,6
412.3*	2	Piston O-ring	Joint de piston	Kolbendichtung	*	Ø 59,69 x 5,33
412.4	2	O-ring	Joint torique	O-Ring	Nitril	Ø 8,90 x 2,7
412.6	2	O-ring	Joint torique	O-Ring	Nitril	Ø 12 x 1,5
412.7	2	O-ring	Joint torique	O-Ring	Nitril	Ø 13,6 x 2,7
486	2	Ball	Bille	Kugel	Stainless steel	
55-2	1	Friction washer	Rondelle de frottement	Unterlegscheibe	Acetal	
593	2	Piston bearing	Segment de piston	Kolbenring	Acetal	
81-68	2	Piston guide	Patin	Gleitschuh	Acetal	
903	2	Plug	Bouchon	Verschlußschraube	Polyamide 6-6	
932	1	Spring retaining ring	Circlips	Sicherungsring	Stainless steel	

CODING CODIFICATION KODIERUNG	Temperature range Plage de température Temperatur	Specificities Spécificités Spezifikationen
42 088 709	-20 °C to • à • bis +80 °C	* O-rings item 412.1 ; 412.2 ; 412.3: Nitril
42 088 865	-40 °C to • à • bis +80 °C	* O-rings item 412.1 ; 412.2 ; 412.3: Nitril low temperature
42 088 866	-20 °C to • à • bis +120 °C	* O-rings item 412.1 ; 412.2 ; 412.3: Viton

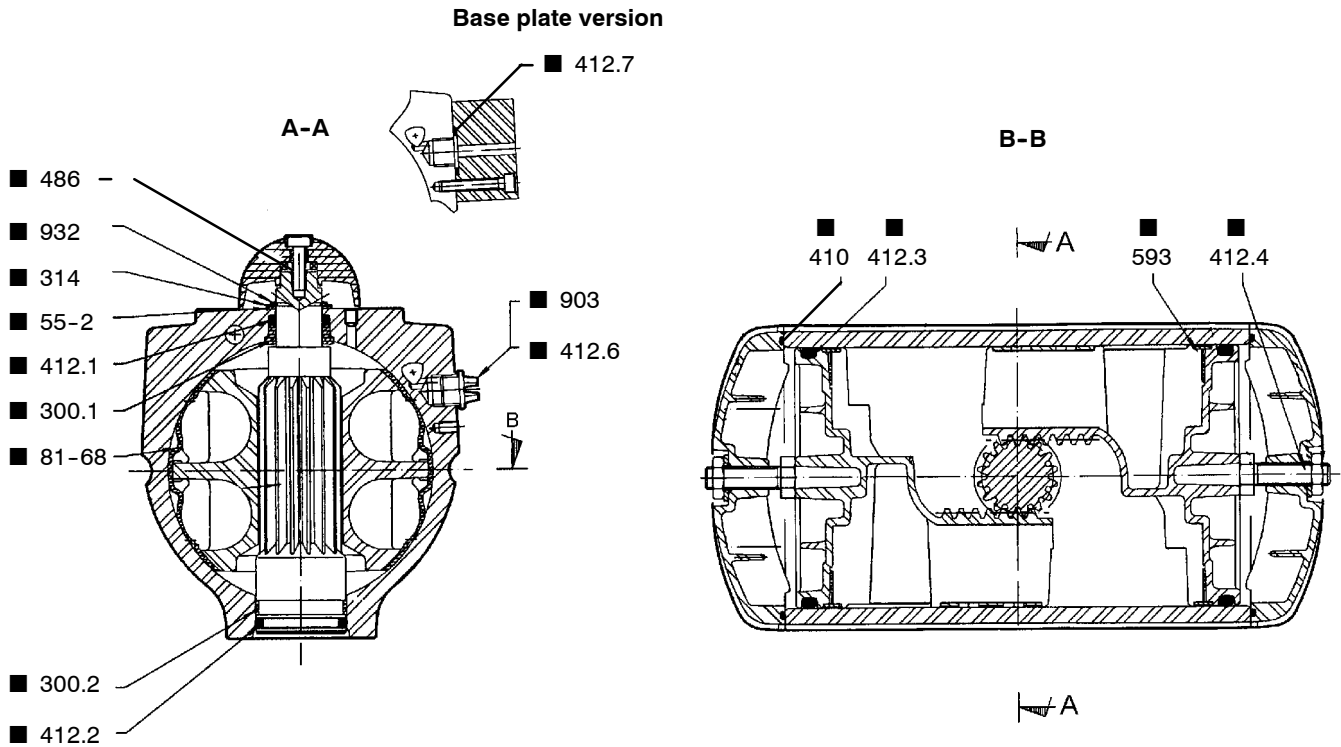

Item*	Qty	Designation	Désignation	Benennung	Materials / Matériaux Werkstoffe	Dimensions (mm)
300.1	1	Upper bearing	Palier supérieur	oberes Lager	Acetal	
300.2	1	Lower bearing	Palier inférieur	unteres Lager	Acetal	
314	1	Thrust washer	Rondelle butée	Anschlagscheibe	Stainless steel	
410	2	Cylinder head gasket	Joint de culasse	Zylinderdeckeldichtung	Nitril	
412.1*	1	O-ring	Joint torique	O-Ring	*	Ø 19,80 x 3,6
412.2*	1	O-ring	Joint torique	O-Ring	*	Ø 27,80 x 3,6
412.3*	2	Piston O-ring	Joint de piston	Kolbendichtung	*	Ø 78,74 x 5,33
412.4	2	O-ring	Joint torique	O-Ring	Nitril	Ø 8,90 x 2,7
412.6	2	O-ring	Joint torique	O-Ring	Nitril	Ø 12 x 1,5
412.7	2	O-ring	Joint torique	O-Ring	Nitril	Ø 13,6 x 2,7
486	2	Ball	Bille	Kugel	Stainless steel	
55-2	1	Friction washer	Rondelle de frottement	Unterlegscheibe	Acetal	
593	2	Piston bearing	Segment de piston	Kolbenring	Acetal	
81-68	2	Piston guide	Patin	Gleitschuh	Acetal	
903	2	Plug	Bouchon	Verschlußschraube	Polyamide 6-6	
932	1	Spring retaining ring	Circlips	Sicherungsring	Stainless steel	

CODING CODIFICATION KODIERUNG	Temperature range Plage de température Temperatur	Specificities Spécificités Spezifikationen
42 088 710	-20 °C to • à • bis +80 °C	* O-rings item 412.1 ; 412.2 ; 412.3: Nitril
42 088 867	-40 °C to • à • bis +80 °C	* O-rings item 412.1 ; 412.2 ; 412.3: Nitril low temperature
42 088 868	-20 °C to • à • bis +120 °C	* O-rings item 412.1 ; 412.2 ; 412.3: Viton

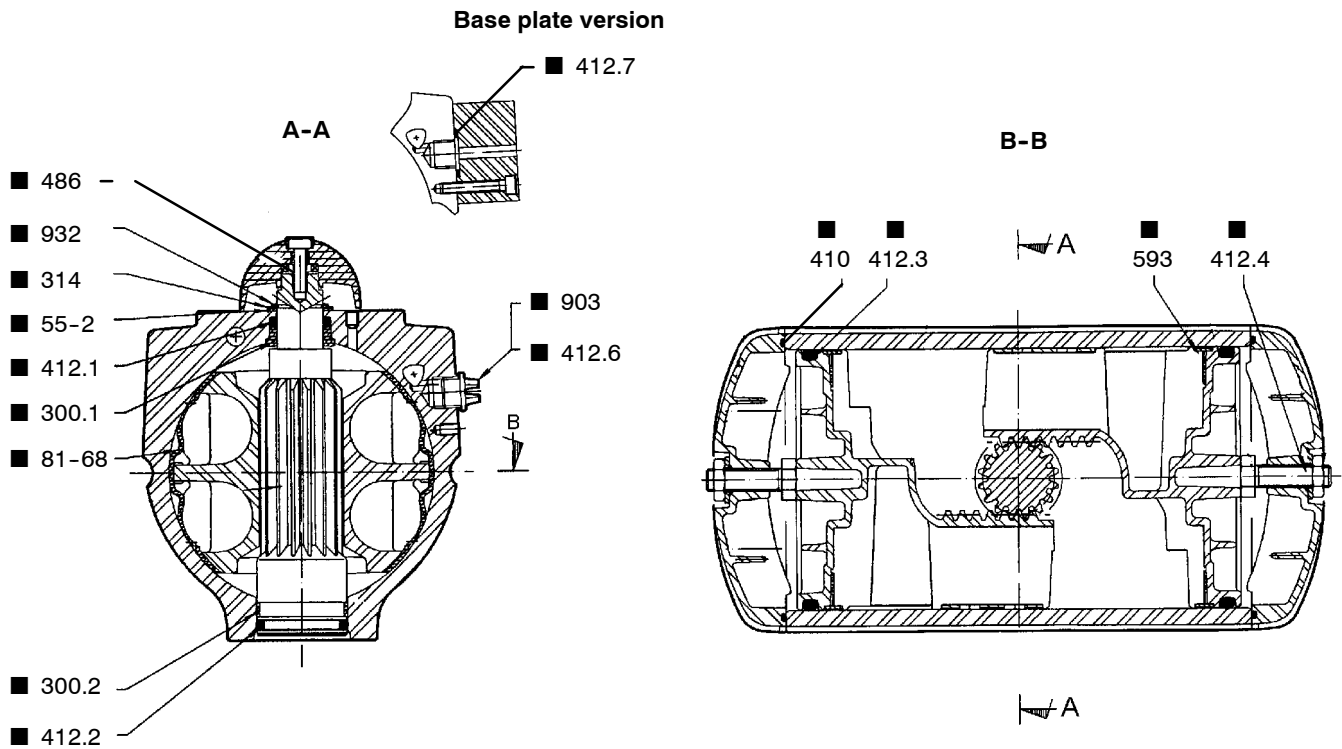

Item*	Qty	Designation	Désignation	Benennung	Materials / Matériaux Werkstoffe	Dimensions (mm)
300.1	1	Upper bearing	Palier supérieur	oberes Lager	Acetal	
300.2	1	Lower bearing	Palier inférieur	unteres Lager	Acetal	
314	1	Thrust washer	Rondelle butée	Anschlagscheibe	Stainless steel	
410	2	Cylinder head gasket	Joint de culasse	Zylinderdeckeldichtung	Nitril	
412.1*	1	O-ring	Joint torique	O-Ring	*	Ø 19,80 x 3,6
412.2*	1	O-ring	Joint torique	O-Ring	*	Ø 32,50 x 3,6
412.3*	2	Piston O-ring	Joint de piston	Kolbendichtung	*	Ø 104,14 x 5,33
412.4	2	O-ring	Joint torique	O-Ring	Nitril	Ø 8,90 x 2,7
412.6	2	O-ring	Joint torique	O-Ring	Nitril	Ø 12 x 1,5
412.7	2	O-ring	Joint torique	O-Ring	Nitril	Ø 13,6 x 2,7
486	2	Ball	Bille	Kugel	Stainless steel	
55-2	1	Friction washer	Rondelle de frottement	Unterlegscheibe	Acetal	
593	2	Piston bearing	Segment de piston	Kolbenring	Acetal	
81-68	2	Piston guide	Patin	Gleitschuh	Acetal	
903	2	Plug	Bouchon	Verschlußschraube	Polyamide 6-6	
932	1	Spring retaining ring	Circlips	Sicherungsring	Stainless steel	

CODING CODIFICATION KODIERUNG	Temperature range Plage de température Temperatur	Specificities Spécificités Spezifikationen
42 088 711	-20 °C to • à • bis +80 °C	* O-rings item 412.1 ; 412.2 ; 412.3: Nitril
42 088 869	-40 °C to • à • bis +80 °C	* O-rings item 412.1 ; 412.2 ; 412.3: Nitril low temperature
42 088 870	-20 °C to • à • bis +120 °C	* O-rings item 412.1 ; 412.2 ; 412.3: Viton

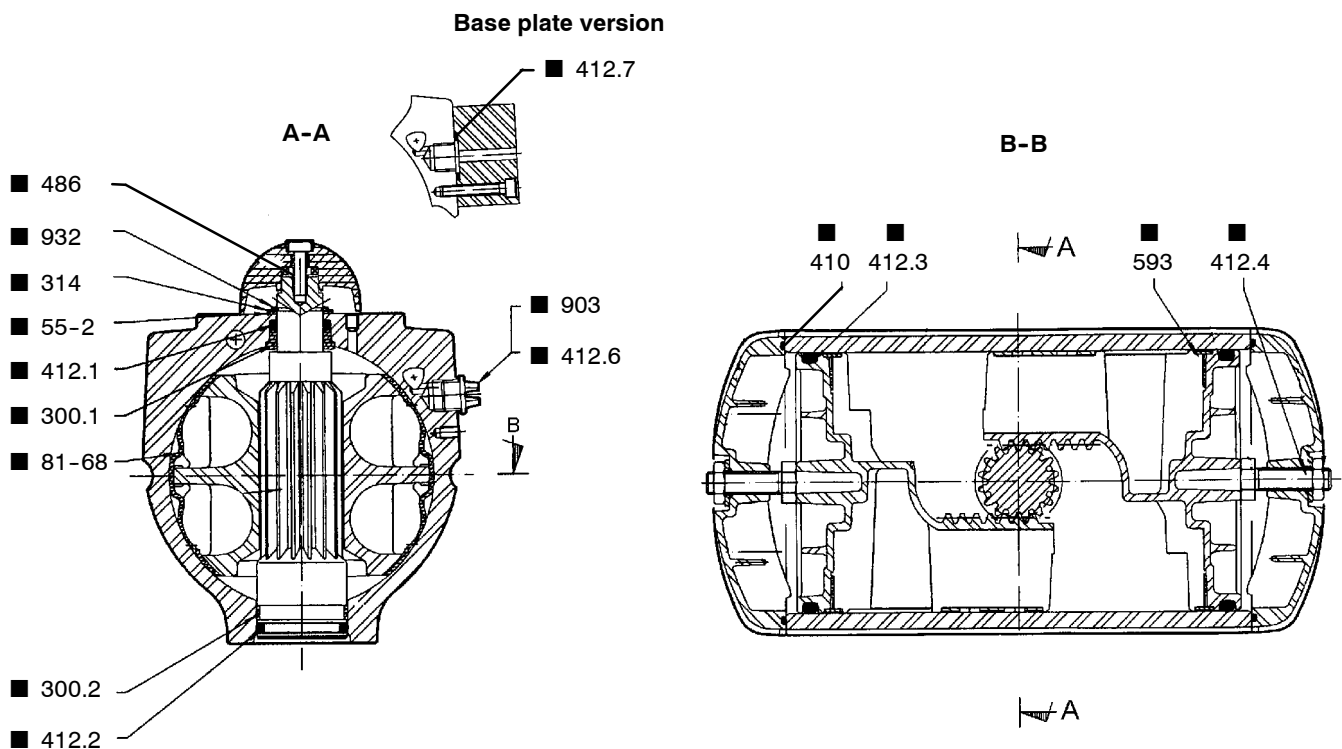

Item*	Qty	Designation	Désignation	Benennung	Materials / Matériaux Werkstoffe	Dimensions (mm)
300.1	1	Upper bearing	Palier supérieur	oberes Lager	Acetal	
300.2	1	Lower bearing	Palier inférieur	unteres Lager	Acetal	
314	1	Thrust washer	Rondelle butée	Anschlagscheibe	Stainless steel	
410	2	Cylinder head gasket	Joint de culasse	Zylinderdeckeldichtung	Nitril	
412.1*	1	O-ring	Joint torique	O-Ring	*	Ø 19,80 x 3,6
412.2*	1	O-ring	Joint torique	O-Ring	*	Ø 40,64 x 5,33
412.3*	2	Piston O-ring	Joint de piston	Kolbendichtung	*	Ø 132,72 x 6,99
412.4	2	O-ring	Joint torique	O-Ring	Nitril	Ø 15,50 x 3,53
412.6	2	O-ring	Joint torique	O-Ring	Nitril	Ø 12 x 1,5
412.7	2	O-ring	Joint torique	O-Ring	Nitril	Ø 13,6 x 2,7
486	2	Ball	Bille	Kugel	Stainless steel	
55-2	1	Friction washer	Rondelle de frottement	Unterlegscheibe	Acetal	
593	2	Piston bearing	Segment de piston	Kolbenring	Acetal	
81-68	2	Piston guide	Patin	Gleitschuh	Acetal	
903	2	Plug	Bouchon	Verschlußschraube	Polyamide 6-6	
932	1	Spring retaining ring	Circlips	Sicherungsring	Stainless steel	

CODING CODIFICATION KODIERUNG	Temperature range Plage de température Temperatur	Specificities Spécificités Spezifikationen
42 088 712	-20 °C to • à • bis +80 °C	* O-rings item 412.1 ; 412.2 ; 412.3: Nitril
42 088 871	-40 °C to • à • bis +80 °C	* O-rings item 412.1 ; 412.2 ; 412.3: Nitril low temperature
42 088 872	-20 °C to • à • bis +120 °C	* O-rings item 412.1 ; 412.2 ; 412.3: Viton

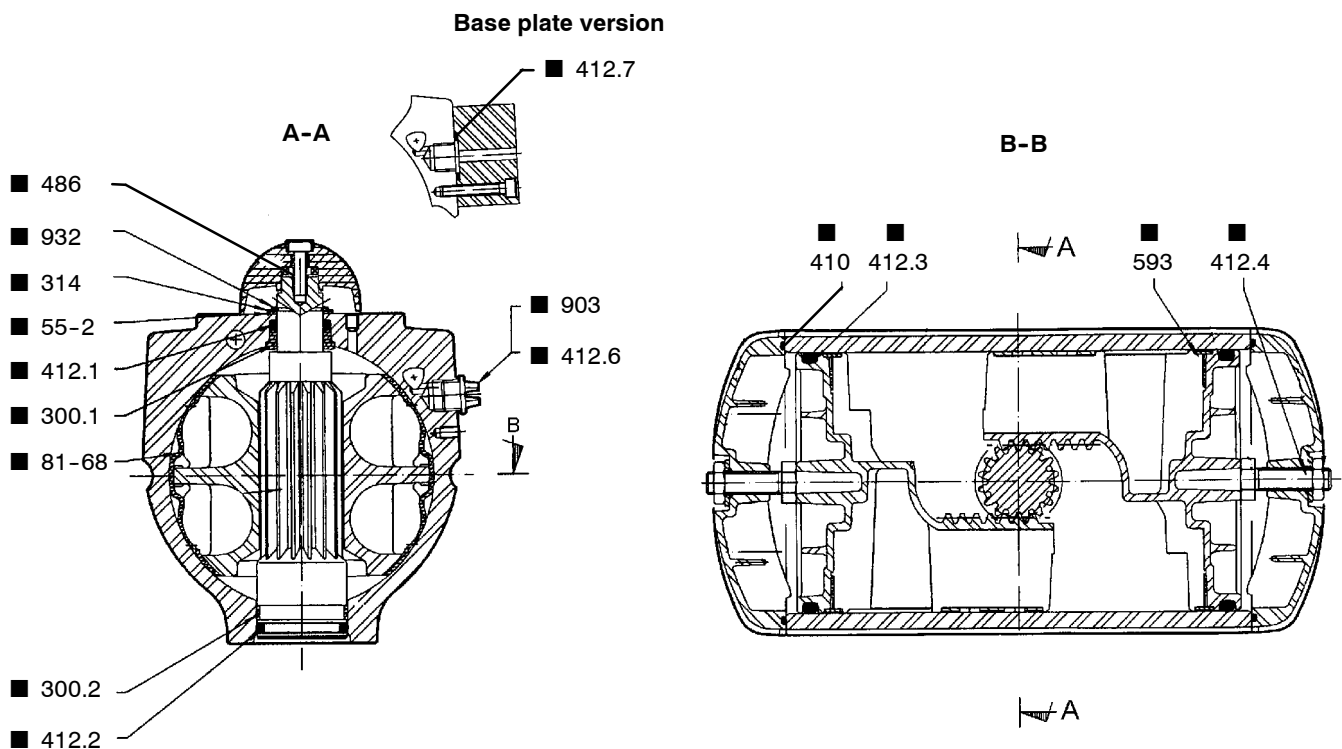

Item*	Qty	Designation	Désignation	Benennung	Materials / Matériaux Werkstoffe	Dimensions (mm)
300.1	1	Upper bearing	Palier supérieur	oberes Lager	Acetal	
300.2	1	Lower bearing	Palier inférieur	unteres Lager	Acetal	
314	1	Thrust washer	Rondelle butée	Anschlagscheibe	Stainless steel	
410	2	Cylinder head gasket	Joint de culasse	Zylinderdeckeldichtung	Nitril	
412.1*	1	O-ring	Joint torique	O-Ring	*	Ø 30,80 x 3,6
412.2*	1	O-ring	Joint torique	O-Ring	*	Ø 53,34 x 5,33
412.3*	2	Piston O-ring	Joint de piston	Kolbendichtung	*	Ø 164,47 x 6,99
412.4	2	O-ring	Joint torique	O-Ring	Nitril	Ø 15,50 x 3,53
412.6	2	O-ring	Joint torique	O-Ring	Nitril	Ø 12 x 1,5
412.7	2	O-ring	Joint torique	O-Ring	Nitril	Ø 13,6 x 2,7
486	2	Ball	Bille	Kugel	Stainless steel	
55-2	1	Friction washer	Rondelle de frottement	Unterlegscheibe	Acetal	
593	2	Piston bearing	Segment de piston	Kolbenring	Acetal	
81-68	2	Piston guide	Patin	Gleitschuh	Acetal	
903	2	Plug	Bouchon	Verschlußschraube	Polyamide 6-6	
932	1	Spring retaining ring	Circlips	Sicherungsring	Stainless steel	

This leaflet is not contractual
and may be amended without notice.

29.11.13

8515.81/5-EN



KSB S.A.S
4, allée des Barbanniers • 92635 Gennevilliers Cedex (France)
Tel. : +33 1 41 47 75 00 • Fax : +33 1 41 47 75 10 • www.ksb.com

