

Dual-plate Check Valve

SERIE 2000

PN 16 / PN 25 / Class 150
DN 50-600 (2"-24")
Class 300
DN 50-300 (2"-12")

Type Series Booklet



Legal information/Copyright

Type Series Booklet SERIE 2000

All rights reserved. The contents provided herein must neither be distributed, copied, reproduced, edited or processed for any other purpose, nor otherwise transmitted, published or made available to a third party without the manufacturer's express written consent.

Subject to technical modification without prior notice.

© KSB S.A.S, Gennevilliers (Paris), France 22/01/2018

Check Valves and Strainers

Dual-plate Check Valve

SERIE 2000



Main applications

- Air-conditioning systems
- Water supply systems
- Process engineering
- Industrial recirculation systems
- General irrigation systems
- Water treatment
- Seawater desalination/reverse osmosis
- Chemical industry
- Pulp and paper industry
- Petrochemical industry
- Shipbuilding
- Sugar industry
- Hot-water heating systems

Fluids handled

- Volatile fluids

Operating data

Operating properties

Characteristic	Value	
Nominal pressure	PN 16	PN 25
Nominal size	DN 50-600	DN 50-600
Max. permissible pressure	16 bar	25 bar
Max. permissible temperature	200 °C	343 °C
Min. permissible temperature	-5 °C	-18 °C

Characteristic	Value	
Nominal pressure	Class 150	Class 300
Nominal size	DN 50-600	DN 50-300
Max. permissible pressure	20 bar	50 bar
Max. permissible temperature	538 °C	538 °C
Min. permissible temperature	-196 °C	-196 °C

Design details

Design

- Single-piece wafer-type body for long operating reliability and corrosion protection
- Dual-plate design
- Two types of seat/disc interface:
 - Metal/elastomer: SERIE 2000 - PN 16 / PN 25 / Class 150 / Class 300
 - Metal/metal: SERIE 2000 PN 25 / Class 150 / Class 300
- Tight shut-off
 - SERIE 2000 PN 16 / PN 25 / Class 150 / Class 300: Metal/elastomer-seated to EN 12266-1 leakage rate A and ISO 5208 category A
 - SERIE 2000 PN 25 / Class 150 / Class 300: Metal/metal-seated to API 598
- Face-to-face length to API 594 for version:
 - PN 16 (Class 125 except DN 65 to 300 (2 ½" to 12"))
 - PN 25 (Class 150)
 - Class 150
 - Class 300
- Installation between flanges to PN 10, 16, 25 and ASME B16.5 Class 150
- Marked in accordance with EN 19
- Exterior coating: polyurethane coating, thickness 80 µm, RAL 5002 blue
- Exterior coating of stainless steel bodies: no coating required due to pickling and passivation
- The valves satisfy the safety requirements of Annex I of the European Pressure Equipment Directive 2014/68/EU (PED) for fluids in Groups 1 and 2.
- The valves meet the requirements of the REACH 1907/2006 regulation. None of the substances listed in the candidate list and in Annex XIV of the regulation is present in a concentration above 0.1 % (w/w) (Article 33/REACH).

Variants

- ATEX-compliant version in accordance with the 2014/34/EU Directive
- On request:
 - SERIE 2000 PN 25 / Class 150: DN 700-1200 (28"-48")
 - SERIE 2000 Class 300: DN 350-600 (14"-24")
- Version to RCC-M and ASME for use in the nuclear sector

Body materials

Overview of available materials

Material	Material number	Temperature limit
SERIE 2000 PN 16		
ASTM A126 Cl. B	JL 1040	< 200 °C
SERIE 2000 PN 25		
ASTM A395	JS 1030	< 343 °C
SERIE 2000 Class 150 / Class 300		
ASTM A216 WCC	1.0619	< 427 °C
ASTM A351 CF8M	1.4408	< 538 °C
ASTM B148 C95800 / CC 333G		< 350 °C

Product benefits

- Low weight and compact design.
- No additional support of piping required.
- No special tools required for installation.

- Very long service life and excellent corrosion resistance.
- Design prevents friction and resulting damage to seat/disc interface.

Related documents

Document	Reference No.
Operating manual	8000.86

Purchase order specifications

1. Type series
2. Nominal pressure
3. Nominal size
4. Fluid handled
5. Flow rate/velocity
6. Temperature
7. Materials required (body, valve disc, seat)
8. Mating dimensions
9. Reference number of type series booklet

Pressure/temperature ratings
PN 16

In pressure class PN 16, SERIE 2000 dual-plate check valves meet the requirements of the EN 12516-4 standard.

Material		Operating pressure in bar at a temperature in °C					
Body	Seat	-5	50	100	120	150	200
ASTM A126 Cl. B	Nitrile (K)	16	16	16	Not permitted		
	EPDM (X)	16	16	16	16	Not permitted	
	VITON (V)	16	16	16	16	14,3	12,7

PN 25

In pressure class PN 25, SERIE 2000 dual-plate check valves meet the requirements of the EN 12516-1 standard.

Material		Operating pressure in bar at a temperature in °C											
Body	Seat	-18	-5	38	50	93	100	120	150	200	250	300	343
ASTM A395	Metal/metal (M)	25	25	25	22,6	16,2	15,9	15,4	14,8	13,8	11,8	9,8	8,6
	Nitrile (K)	25	25	25	22,6	16,2	15,9	Not permitted					
	EPDM (X)	25	25	25	22,6	16,2	15,9	15,4	Not permitted				
	VITON (V)	Not permitted	25	25	22,6	16,2	15,9	15,4	14,8	13,8	Not permitted		

Class 150

In pressure class "Class 150" (European materials), SERIE 2000 dual-plate check valves meet the requirements of EN 12516-1. The values must be adhered to if the dual-plate check valves are to comply with Pressure Equipment Directive 2014/68/EU.

Material		Operating pressure in bar at a temperature in °C																			
Body	Seat	-196	-40	-20	-10	-5	20	50	100	120	150	200	250	300	350	375	400	450	500	525	
1.0619	Metal/metal (M))		19,5	19,5	19,5	18,6	17,1	16,5	15,8	14,2	13,0	11,8	11,0	10,8	10,6)		
	Nitrile (K))		19,5	19,5	19,5	18,6	17,1)											
	EPDM (X))		19,5	19,5	19,5	18,6	17,1	16,5)										
	VITON (V))		19,5	19,5	18,6	17,1	16,5	15,8	14,2)									
1.4408	Metal/metal (M)	19,4	19,4	19,4	19,4	19,4	19,4	18,5	16,6	15,9	15,0	13,7	12,8	12,0	11,4	11,2	10,9	10,7	10,4	8,8	
	Nitrile (K))		19,4	19,4	19,4	18,5	16,6)											
	EPDM (X))	19,4	19,4	19,4	19,4	18,5	16,6	15,9	15,9)										
	VITON (V))		19,4	19,4	18,5	16,6	15,9	15,9	15,0	13,7)								

In pressure class "Class 150" (ASTM materials), SERIE 2000 dual-plate check valves meet the requirements of ASME B16-34 "Standard Class 150" in acc. with the following table:

Material		Operating pressure in bar at a temperature in °C																		
Body	Seat	-196	-40	-29	-20	-5	38	100	120	149	204	260	316	343	371	399	427	454	482	538
A 216 Gr WCC	Metal/metal (M))		20,0	20,0	20,0	20,0	17,7	16,9	15,9	13,8	11,7	9,7	8,6	7,6	6,6	5,5)
	Nitrile (K))		20,0	20,0	20,0	17,7)											
	EPDM (X))		20,0	20,0	20,0	17,7	16,9)										
	VITON (V))		20,0	20,0	17,7	16,9	15,9	13,8	14,2)								
A 351 Gr CF8M	Metal/metal (M)	19,0	19,0	19,0	19,0	19,0	19,0	16,2	15,6	14,8	13,4	11,7	9,7	8,6	7,6	6,6	5,5	4,5	3,4	1,4
	Nitrile (K))		19,0	19,0	19,0	16,2)											
	EPDM (X))	19,0	19,0	19,0	19,0	19,0	16,2	15,6)										
	VITON (V))		19,0	19,0	16,2	15,6	14,8	13,4)									

Material		Operating pressure in bar at a temperature in °C														
Body	Seat	-10	-5	100	120	150	180	200	220	250	260	280	300	320	350	
B148 C95800 / CC333G	Metal/metal (M)	19,4	19,4	16,0	16,0	16,0	16,0	15,0	14,0	13,0	12,0	11,0	10,0	8,5	7,0	
	Nitrile (K)	19,4	19,4	16,0)											
	EPDM (X)	19,4	19,4	16,0	16,0)										
	VITON (V))	19,4	16,0	16,0	16,0	16,0	16,0)							

1) Not permitted

Class 300

In pressure class "Class 300" (European materials), SERIE 2000 dual-plate check valves meet the requirements of EN 12516-1. The values must be adhered to if the dual-plate check valves are to comply with Pressure Equipment Directive 2014/68/EU.

Material		Operating pressure in bar at a temperature in °C																		
Body	Seat	-196	-40	-20	-10	-5	20	50	100	120	150	200	250	300	350	375	400	450	500	525
1.0619	Metal/metal (M)				49,4	49,4	49,4	47,1	43,2	41,7	40,1	36,0	32,9	29,8	27,8	27,4	26,7			
	Nitrile (K)				49,4	49,4	49,4	47,1	43,2											
	EPDM (X)				49,4	49,4	49,4	47,1	43,2	41,7										
	VITON (V)				49,4	49,4	47,1	43,2	41,7	40,1	36,0									
1.4408	Metal/metal (M)	49,2	49,2	49,2	49,2	49,2	49,2	46,8	42,0	40,1	37,9	34,8	32,4	30,5	28,8	28,3	27,6	27,1	26,4	22,2
	Nitrile (K)			49,2	49,2	49,2	49,2	46,8	42,0											
	EPDM (X)		49,2	49,2	49,2	49,2	49,2	46,8	42,0	40,1										
	VITON (V)				49,2	49,2	46,8	42,0	40,1	37,9	34,8									

In pressure class "Class 300" (ASTM materials), SERIE 2000 dual-plate check valves meet the requirements of ASME B16-34 "Standard Class 300" in acc. with the following table:

Material		Operating pressure in bar at a temperature in °C																		
Body	Seat	-196	-40	-29	-20	-5	38	100	120	149	204	260	316	343	371	399	427	454	482	538
A 216 Gr WCC	Metal/metal (M)			51,7	51,7	51,7	51,7	51,5	51,0	50,3	48,6	45,9	41,7	40,7	39,3	34,8	28,3			
	Nitrile (K)			51,7	51,7	51,7	51,5													
	EPDM (X)			51,7	51,7	51,7	51,7	51,5	51,0											
	VITON (V)				51,7	51,7	51,5	51,0	50,3	48,6										
A 351 Gr CF8M	Metal/metal (M)	49,6	49,6	49,6	49,6	49,6	49,6	42,7	40,8	38,6	35,5	33,1	31,0	30,7	29,6	29,3	29,0	29,0	28,6	24,1
	Nitrile (K)				49,6	49,6	49,6	42,7												
	EPDM (X)		49,6	49,6	49,6	49,6	49,6	42,7	40,8											
	VITON (V)				49,6	49,6	42,7	40,8	38,6	35,5										

Material		Operating pressure in bar at a temperature in °C														
Body	Seat	-10	-5	100	120	150	180	200	220	250	260	280	300	320	350	
B148 C95800 / CC333G	Metal/metal (M)	49,6	49,6	40	40	38,5	35,5	33,5	31	28	26,5	24,5	22,5	20	17,5	
	Nitrile (K)	49,6	49,6	40												
	EPDM (X)	49,6	49,6	40	40											
	VITON (V)		49,6	40	40	38,5	35,5	33,5								

Pressure losses as a function of flow rate

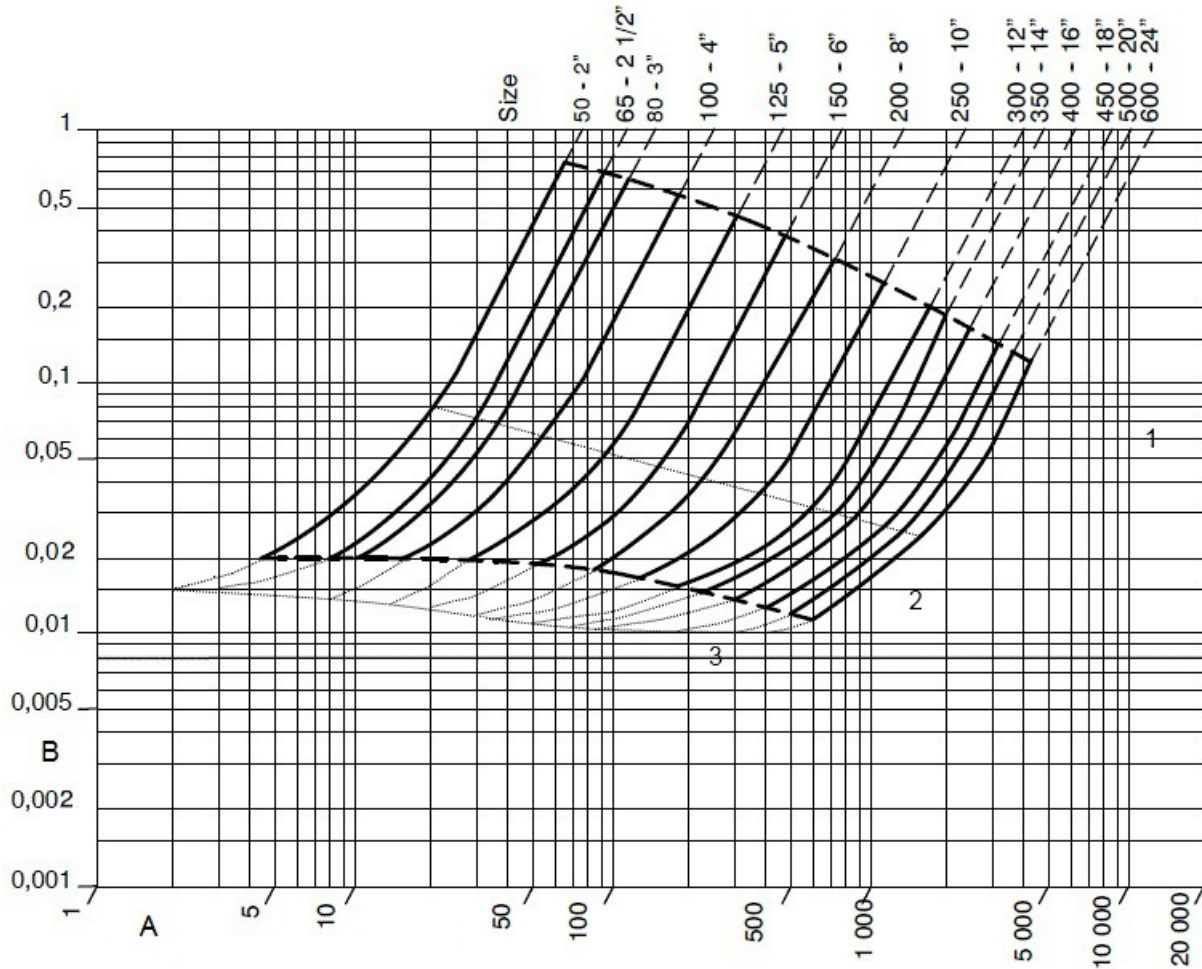

- A: Flow rate in m³/h
- B: * Pressure loss in bar
- 1 : Valve fully open: stable
- 2 : Valve partially open: stable
- 3 : Valve partially open (operation at low velocity is possible, but pressure may fluctuate).

The continuous curves represent the flow rate range for optimum use of the dual-plate check valve.

Materials

Sectional drawing

PN 16 / PN 25 / Class 150: DN 50-350 and 450
Class 300 : DN 50-300
(single spring)

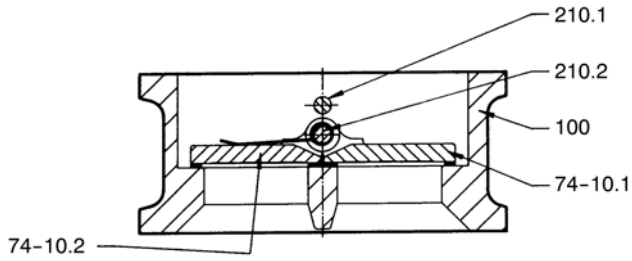

PN 16 / PN 25 / Class 150: DN 400, 500 and 600
(double spring)

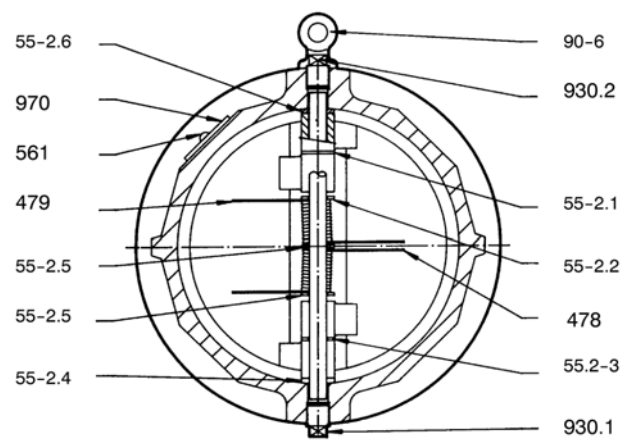
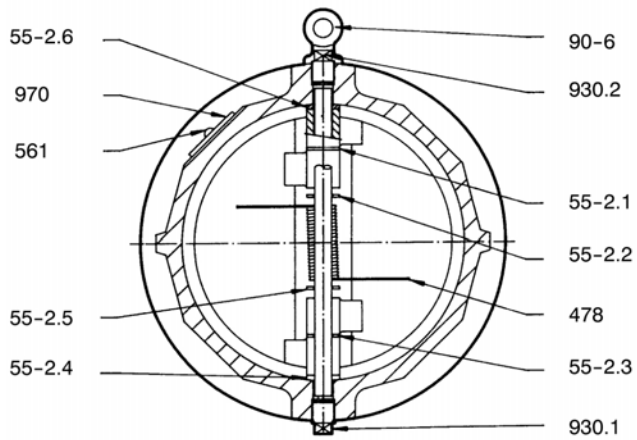
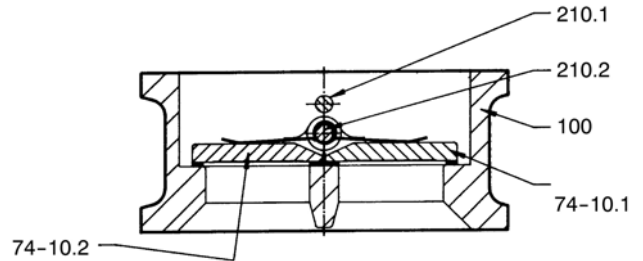

List of components

Part No.	Description	DN	Materials	KSB code
100	Body	50-600	Lamellar graphite cast iron ASTM A126 Cl. B	3t ²⁾
100	Body	50-600	Nodular cast iron ASTM A395	3g ³⁾
100	Body	50-600	Steel ASTM A216 Gr. WCC / 1.0619	1 ⁴⁾⁵⁾
100	Body	50-600	Stainless steel ASTM A351 Gr. CF8M / 1.4408	6 ⁴⁾⁵⁾
100	Body	50-600	Copper aluminium B148 C95800 / CC333G	2 ⁴⁾⁵⁾
210.1	Stop pin	50-600	Stainless steel 316	
210.2	Hinge pin	50-600	Stainless steel 316	
55-2.1	Anti-friction disc	50-600	Seats K, X, V: reinforced PTFE Seat M: stainless steel 361L	
55-2.2	Anti-friction disc	50-600	Seats K, X, V: reinforced PTFE Seat M: stainless steel 361L	
55-2.3	Anti-friction disc	50-600	Seat M: stainless steel 361L Seats K, X, V: reinforced PTFE	
55-2.4	Anti-friction disc	50-600	Seat M: stainless steel 361L Seats K, X, V: reinforced PTFE	
55-2.5	Anti-friction disc	50-600	Seat M: stainless steel 361L Seats K, X, V: reinforced PTFE	
55-2.6	Anti-friction disc	50-600	Seat M: stainless steel 361L Seats K, X, V: reinforced PTFE	
55-2.7	Anti-friction disc	400, 500 and 600	Seat M: stainless steel 361L Seats K, X, V: reinforced PTFE	
561	Half round head grooved pin	50-600	Stainless steel	
74-10.1	Plate	50-600	Stainless steel ASTM A351 Gr. CF8M ⁶⁾	6
74-10.1	Plate	50-600	Nodular cast iron ASTM A395 (DN => 250)	3g
74-10.1	Plate	50-600	Copper aluminium ASTM B148 C95800 ⁷⁾	2
74-10.1	Plate	50-600	Steel ASTM A216 Gr. WCC / 1.0619 (DN=>350) ⁸⁾	1
74-10.2	Plate	50-600	Stainless steel ASTM A351 Gr. CF8M ⁶⁾	6
74-10.2	Plate	50-600	Nodular cast iron ASTM A395 (DN => 250)	3g
74-10.2	Plate	50-600	Copper aluminium ASTM B148 C95800 ⁷⁾	2
74-10.2	Plate	50-600	Steel ASTM A216 Gr. WCC / 1.0619 (DN=>350) ⁸⁾	1
90-6	Eyebolt	200-600	Carbon steel	
930.1	Pin retainer (stop pin)	50-450 500 and 600	Carbon steel Stainless steel	
930.2	Pin retainer (hinge pin)	50-450 500 and 600	Carbon steel Stainless steel	
970	Name plate	50-600	Stainless steel	

SERIE 2000 PN 16 / PN 25 / Class 150:

Dual-plate check valve with seat made of Nitrile HT (KSB code: K) or EPDM (KSB code: X)

Part No.	Description	DN	Materials	KSB code
478	Spring (right-hand)	50-600	Stainless steel 316	
479	Spring (left-hand)	400, 500 and 600	Stainless steel 316	

SERIE 2000 Class 300:

Dual-plate check valve with seat made of Nitrile HT (KSB code K) or EPDM (KSB code X) or HYPALON (KSB code Y)

Part No.	Description	DN	Materials	KSB code
478	Spring (right-hand)	50-300	Stainless steel 316	

2) For SERIE 2000 PN 16

3) For SERIE 2000 PN 25

4) For SERIE 2000 Class 150

5) For SERIE 2000 Class 300

6) Can be used for bodies made of steel ASTM A216 Gr. WCC / 1.0619 or stainless steel A351 Gr. CF8M / 1.4408 for SERIE 2000 Class 150

7) Can be used for bodies made of steel ASTM A216 Gr. WCC / 1.0619 or stainless steel A351 Gr. CF8M / 1.4408 or copper aluminium B148 C95800 / CC333G for SERIE 2000 Class 150

8) Can be used for bodies made of steel ASTM A216 Gr. WCC / 1.0619 for SERIE 2000 Class 150

SERIE 2000 PN 16:

Dual-plate check valve with seat made of VITON (KSB code: V)

Part No.	Description	DN	Materials	KSB code
478	Spring (right-hand)	50-600	Inconel 600	
479	Spring (left-hand)	400, 500 and 600	Inconel 600	

SERIE 2000 PN 25 / Class 150 / Class 300:

Dual-plate check valve with seat made of VITON (KSB code: V) or metal-seated (KSB code: M)

Part No.	Description	DN	Materials	KSB code
478	Spring (right-hand)	50-600	Inconel 600	
479	Spring (left-hand)	400, 500 and 600	Inconel 600	

Dimensions

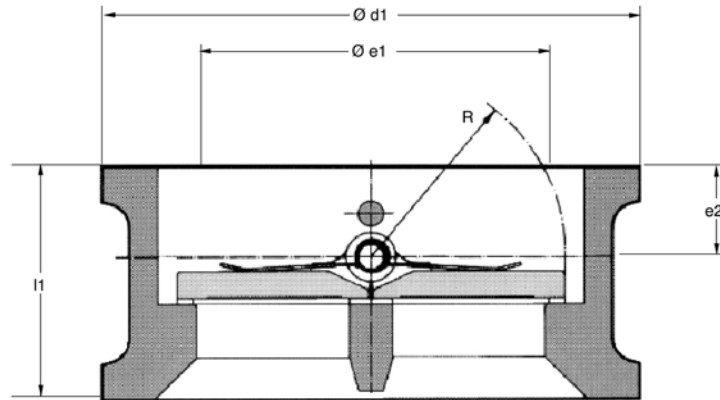

PN 16

DN	NPS	PN	Dimensions		Plate		
			Ø d1	l1	e1	e2	R
50	2	10/16	110	54	35	25,8	30
65	2½	10/16	130	54	57	26,0	36
80	3	10/16	145	57	75	25,6	42
100	4	10/16	165	64	99	29,6	54
125	5	10/16	195	70	123	30,8	65
150	6	10/16	221	76	155	28,8	79
200	8	10/16	276	95	198	40,0	103
250	10	10	329	108	248	39,9	127
300	12	10	381	143	291	56,8	153
350	14	10	440	184	302	93,9	175
400	16	10	491	191	366	89,9	200
450	18	10	541	203	422	86,1	224
500	20	10	596	213	471	94,3	250
600	24	10	698	222	577	87,5	298
250	10	16	331	108	248	39,9	127
300	12	16	386	143	291	56,8	153
350	14	16	446	184	302	93,9	175
400	16	16	498	191	366	89,9	200
450	18	16	558	203	422	86,1	224
500	20	16	620	213	471	94,3	250
600	24	16	737	222	577	87,5	298

PN 25

Dimensions in mm

DN	NPS	PN	Dimensions		Plate		
			Ø d1	l1	e1	e2	R
50	2	25	104,6	60	-	33,6	30
65	2½	25	123,7	67	36	32,6	36
80	3	25	136,4	73	50	36,3	42
100	4	25	170	73	84	38,6	54
125	5	25	194	86	107	42,7	65
150	6	25	226	98	142	44,6	81
200	8	25	286	127	191	48,3	104
250	10	25	343	146	238	56,0	128
300	12	25	403	181	280	70,4	154
350	14	25	460	184	307	91,0	175
400	16	25	517	191	379	77,1	201
450	18	25	567	203	431	76,5	225
500	20	25	627	219	482	81,5	251
600	24	25	734	222	585	76,4	299

Class 150

Dimensions in mm

DN	NPS	PN	Dimensions		Plate		
			Ø d1	l1	e1	e2	R
50	2	25	104,6	60	-	33,6	30
65	2½	25	123,7	67	36	32,6	36
80	3	25	136,4	73	50	36,3	42
100	4	25	174,5	73	84	38,6	54
125	5	25	194	86	107	42,7	65
150	6	25	220	98	142	44,6	81
200	8	25	275	127	191	48,3	104
250	10	25	330	146	238	56,0	128
300	12	25	409,5	181	280	70,4	154
350	14	25	450,8	184	307	91,0	175
400	16	25	514,4	191	379	77,1	201
450	18	25	549,3	203	431	76,5	225
500	20	25	606,4	219	482	81,5	251
600	24	25	717,5	222	585	76,4	299

Class 300

Dimensions in mm

DN	NPS	PN	Dimensions		Plate		
			Ø d1	l1	e1	e2	R
50	2	50	111,0	60	-	33,6	30
65	2½	50	129,2	67	36	32,6	36
80	3	50	148,3	73	50	36,3	42
100	4	50	180,0	73	84	38,6	54
125	5	50	215,0	86	107	42,7	65
150	6	50	249,9	98	142	44,6	81
200	8	50	306,2	127	191	48,3	104
250	10	50	360,4	146	238	56,0	128
300	12	50	420,8	181	280	70,4	154

Installation information
Connections and weights
PN 16

DN	NPS	Connection						Weight ⁹⁾ [kg]
		PN 10		PN 16		Class 125		
		Ø d1	l1	Ø d1	l1	Ø d1	l1	
50	2	110	54	110	54	104,9	54	1,5
65	2½	130	54	130	54	123,9	54	2,8
80	3	145	57	145	57	136,6	57	3,6
100	4	165	64	165	64	174,7	64	4,5
125	5	195	70	195	70	196,8	70	6,5
150	6	221	76	221	76	222,2	76	9
200	8	276	95	276	95	279,4	95	16
250	10	329	108	331	108	339,5	108	27
300	12	381	143	386	143	409,4	143	42
350	14	440	184	446	184	450,8	184	77
400	16	491	191	498	191	514,3	191	107
450	18	541	203	558	203	536,7	203	134
500	20	596	213	620	213	606,5	213	170
600	24	698	222	737	222	717,5	222	254

PN 25

DN	NPS	Connection										Weight [kg]
		PN 10		PN 16		PN 20		PN 25		Class 150		
		Ø d1	l1	Ø d1	l1	Ø d1	l1	Ø d1	l1	Ø d1	l1	
50	2	104,6	60	104,6	60	104,6	60	104,6	60	104,6	60	2,3
65	2½	123,7	67	123,7	67	123,7	67	123,7	67	123,7	67	2,7
80	3	136,4	73	136,4	73	136,4	73	136,4	73	136,4	73	3
100	4	164	73	164	73	174,5	73	170	73	174,5	73	6
125	5	194	86	194	86	194	86	194	86	194	86	10
150	6	220	98	220	98	220	98	226	98	220	98	13,3
200	8	275	127	275	127	275	127	286	127	275	127	25
250	10	330	146	330	146	330	146	343	146	330	146	39
300	12	380	181	380	181	407,8	181	403	181	409,5	181	68
350	14	440	184	446	184	449,2	184	460	184	450,8	184	79
400	16	491	191	498	191	512,8	191	517	191	514,4	191	109
450	18	541	203	558	203	547,8	203	567	203	549,3	203	125
500	20	596	219	620	219	605	219	627	219	606,4	219	171
600	24	698	222	737	222	716,3	222	734	222	717,5	222	245

9) Mean weight of dual-plate check valves with mating dimensions in compliance with pressure class

Class 150

DN	NPS	Connection										Weight [kg]
		PN 10		PN 16		PN 20		PN 25		Class 150		
		Ø d1	l1	Ø d1	l1	Ø d1	l1	Ø d1	l1	Ø d1	l1	
50	2	104,6	60	104,6	60	104,6	60	104,6	60	104,6	60	2,5
65	2½	123,7	67	123,7	67	123,7	67	123,7	67	123,7	67	3
80	3	136,4	73	136,4	73	136,4	73	136,4	73	136,4	73	3,4
100	4	164	73	164	73	174,5	73	170	73	174,5	73	6,5
125	5	194	86	194	86	194	86	194	86	194	86	11
150	6	220	98	220	98	220	98	226	98	220	98	14,5
200	8	275	127	275	127	275	127	286	127	275	127	28
250	10	330	146	330	146	330	146	343	146	330	146	43
300	12	380	181	380	181	407,8	181	403	181	409,5	181	74
350	14	440	184	446	184	449,2	184	460	184	450,8	184	85
400	16	491	191	498	191	512,8	191	517	191	514,4	191	109
450	18	541	203	558	203	547,8	203	567	203	549,3	203	125
500	20	596	219	620	219	605	219	627	219	606,4	219	171
600	24	698	222	737	222	716,3	222	734	222	717,5	222	245

Class 300

DN	NPS	Connection								Weight [kg]
		PN 25		PN 40		PN 50		Class 150		
		Ø d1	l1	Ø d1	l1	Ø d1	l1	Ø d1	l1	
50	2	109	60	109	60	111	60	111,1	60	3,1
65	2½	129	67	129	67	129,2	67	130,3	67	4
80	3	144	73	144	73	148,3	73	149	73	4,6
100	4	170	73	170	73	180	73	181	73	8
125	5	196	86	196	86	215	86	215,9	86	14
150	6	226	98	226	98	249,9	98	250,6	98	16
200	8	286	127	293	127	306,2	127	307,9	127	32,5
250	10	343	146	355	146	360,4	146	361,9	146	54
300	12	403	181	420	181	420,8	181	422,2	181	86,5

Installation

SERIE 2000 dual-plate check valves are designed for quick and straightforward installation between standard flanges:

- Low weight and compact design
- Installation without additional piping support
- Can be installed in horizontal or vertical pipes
- Easy to install without special tools
- No maintenance required

SERIE 2000 PN 16 dual-plate check valve:

- Standard: with flat faces (FF), flange faces machined to "smooth finish" Ra 3.2 to 6.3 (KSB code 1A)
- Optional: with flat faces (FF), flange faces machined to "stock finish" Ra 6.3 to 12.5 (KSB code 1B)
- On request: with raised faces (RF)

Design of SERIE 2000 PN 25 / Class 150 / Class 300 dual-plate check valve:

- Standard: with flat faces (FF), flange faces machined to "stock finish" Ra 6.3 to 12.5 (KSB code 1B)
- Optional: with flat faces (FF), flange faces machined to "smooth finish" Ra 3.2 to 6.3 (KSB code 1A)
- On request: with raised faces (RF)

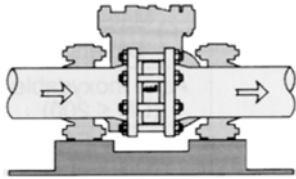

Dead-end service or downstream dismantling

The dual-plate check valves must not be used for dead-end service or downstream dismantling.

Optimum installation (horizontal pipe)

In a horizontal pipe, the dual-plate check valve must be installed with the hinge pin in a vertical position.



CORRECT



INCORRECT

Installation in vertical pipe

When installed in a vertical pipe, the dual-plate check valve will only function reliably if fluid flow is upwards. (Please contact us if flow direction is reversed, i.e. downwards).

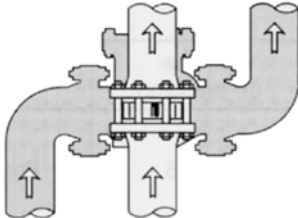
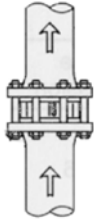

System configuration

Depending on the system configuration, minimum distances must be observed between the dual-plate check valve and elbows or piping tees.

The drawings below show a horizontal pipe (viewed from above) in which the dual-plate check valve is installed with the hinge pin in a vertical position.

The minimum distance for a dual-plate check valve installed downstream of a turbulence-causing element (elbow, pump, valve, etc.) is 5 DN.

If a turbulence-causing element is installed downstream of the dual-plate check valve, any special instructions regarding the respective element or a minimum distance of 2 DN must be observed.

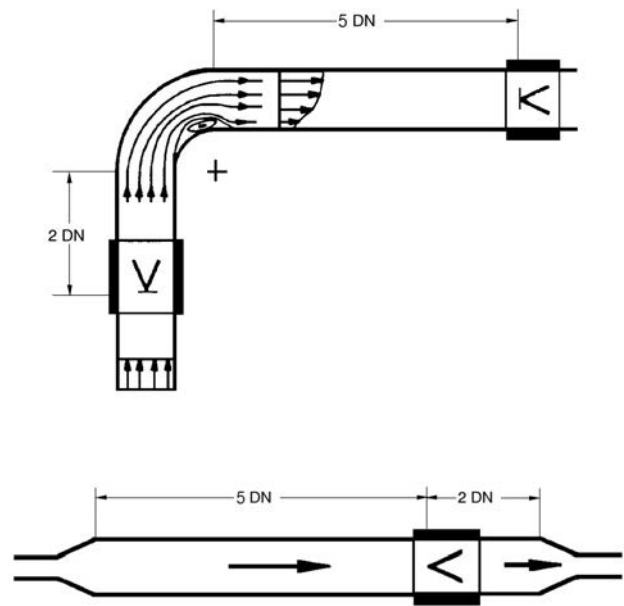
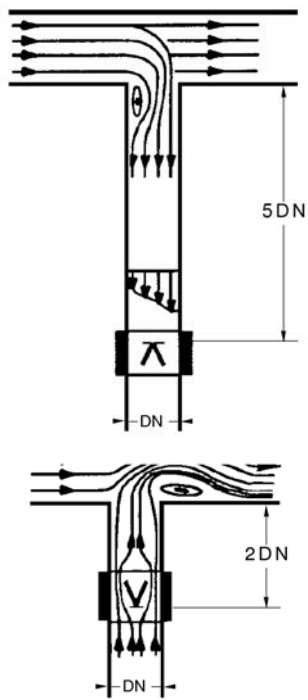



KSB S.A.S.
4, allée des Barbanniers • 92635 Gennevilliers Cedex (France)
Tél. +33 1 41 47 75 00 • Fax +33 1 41 47 75 10
www.ksb.com