

► Our technology. Your success.

Pumps • Valves • Service



Sewatec SPN – Heavy Duty Waste Water Pump



Applications:

- Terminal Pumping Station (Influent)
- Raw Sewage Waste Water Transport
- Combined Sewer Overflow (CSO)
- Storm Water
- Flood Control
- River Water Extraction

More information:

www.ksb.com/products

Sewatec SPN – Heavy Duty Waste Water Pump

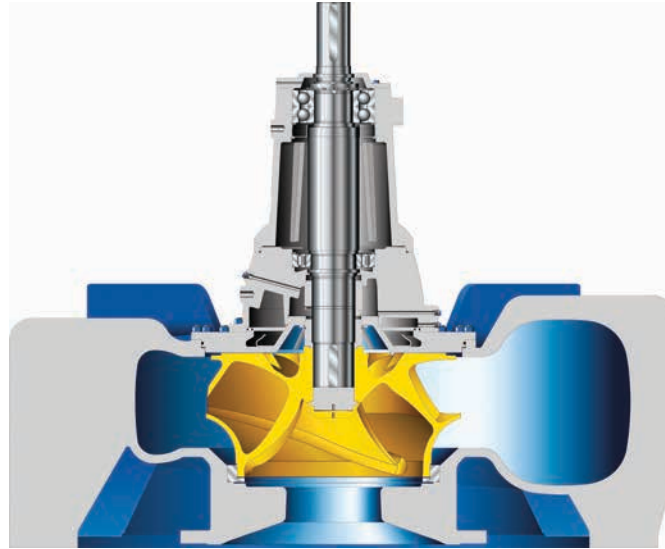

- Proven quality, high operating reliability and environmentally friendly design**
Grease or oil lubricated heavy duty bearings. Double mechanical seals as a standard with zero leakage into the environment. Gland packing or split mechanical seals upon request.
- Minimized Total Costs of Ownership**
No external seal flush/supply system is required.
- Low-maintenance design**
Proven shaft seal concept practically not requiring maintenance. Replaceable Wear rings. Easy accessible cleaning ports.
- Efficient and reliable hydraulic system**
Closed, multivane non-clogging impeller combined with a hydraulically optimised volute casing for efficient handling of waste water
- Variable Installation Types**
Vertical or horizontal. For vertical installation pump casing with foot flange or with ring flange for various discharge angles. Taylor made accelerating suction elbow with EN/ASME flanges and other accessories available.

- Acceptance testing and additional services**
Factory acceptance and performance testing acc. to DIN/ISO and HI or comparable standards. CFD simulations, water hammer and reverse flow calculations and further services upon request.
- Sensor and Instrumentation**
Temperature, vibration and leakage sensors. Other sensors on request.

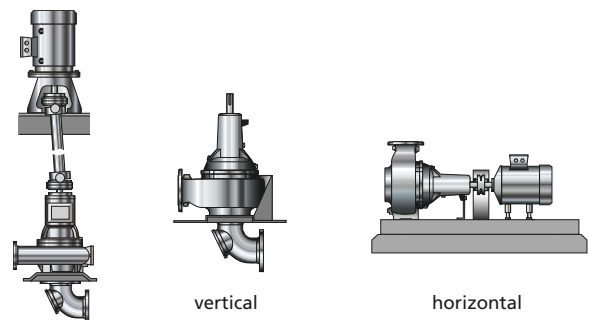

Technical data*

Size	Up to DN 1600
Flow	Up to 9000 l/s
Head	Up to 100 m
Ambient Temperature	Up to +55 °C

*further requirements upon request



KSB SE & Co. KGaA
Johann-Klein-Straße 9
67227 Frankenthal (Germany)
www.ksb.com