

► Our technology. Your success.

Pumps • Valves • Service



Amaprop – Submersible Mixer



Applications:

- Biological treatment
- Sludge storage tanks
- Activated sludge tanks

More information:

www.ksb.com/products

Intelligent monitoring



Amacontrol III – Protection Module
for Water and Waste Water Products

Amaprop – Submersible Mixer

1 Energy-efficient

Electric motor with comparable efficiencies like standard motors according to IEC 60034-30 cable entry.

2 Absolutely break-proof

Self-cleaning ECB propeller: Propeller blades made of glass fibre reinforced epoxy resin with metal hub insert and protective gel coating.

3 Highest safety

Triple dynamic sealing from 2 mechanical seals combined with one radial sealing ring.

4 Perfectly protected

An absolutely water-tight cable entry protects the motor against moisture.

5 Overheating impossible

Temperature sensors monitor any heat build-up in the motor.

6 Firmly installed

Made of innovative NoriRoc® material, the AmaRoc® accessories ensure an even longer service life.

7 Everything under control

A leakage chamber between the oil chamber and the gear unit provides additional safety.

16,000 operating hours without oil change*

* However, at least every three years (lubricant change).

Straightforward installation

Technical data

Speed	24 to 208 1/min
Power rating	0.85 to 20 kW
Nominal propeller diameter	1,000 to 2,500 mm

ATEX-compliant explosion protection
Suitable for frequency inverter operation

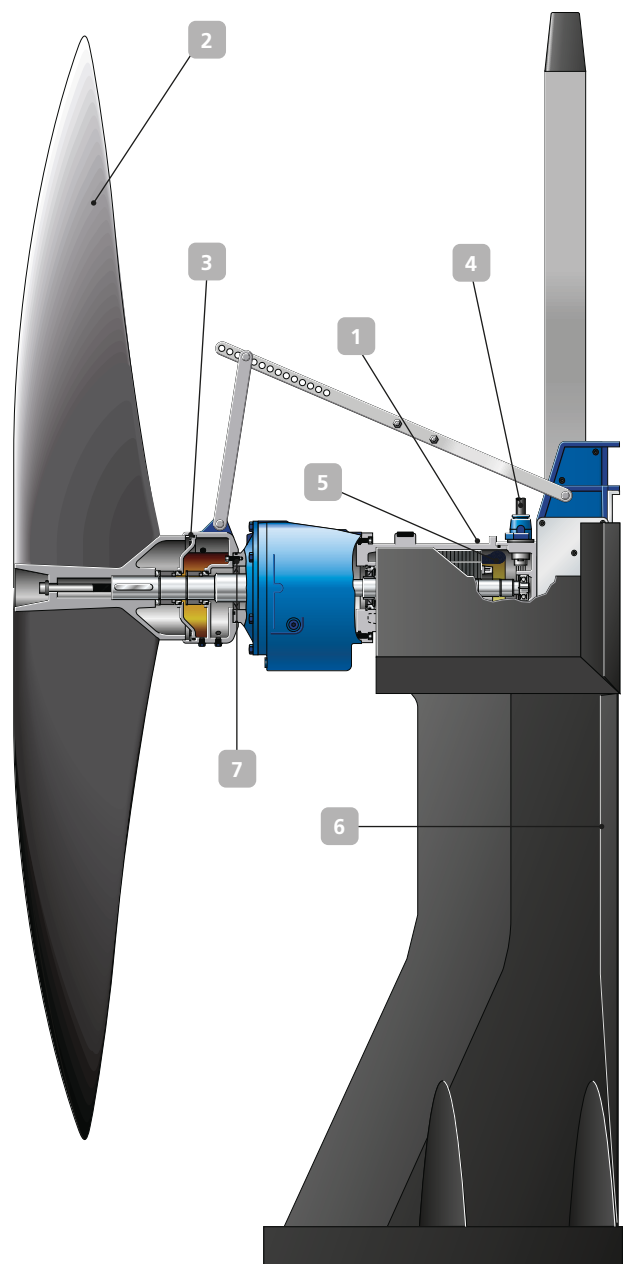

Amaprop 1000



KSB SE & Co. KGaA
Johann-Klein-Straße 9
67227 Frankenthal (Germany)
www.ksb.com