

Process Pump

**RPH**

## Installation/Operating Manual



## **Legal information/Copyright**

Installation/Operating Manual RPH

Original operating manual

All rights reserved. The contents provided herein must neither be distributed, copied, reproduced, edited or processed for any other purpose, nor otherwise transmitted, published or made available to a third party without the manufacturer's express written consent.

Subject to technical modification without prior notice.

© KSB SE & Co. KGaA, Frankenthal 13/07/2018

**Contents**

	<b>Glossary .....</b>	<b>6</b>
<b>1</b>	<b>General.....</b>	<b>7</b>
	1.1 Principles .....	7
	1.2 Installation of partly completed machinery.....	7
	1.3 Target group.....	7
	1.4 Other applicable documents.....	7
	1.5 Symbols .....	7
	1.6 Key to safety symbols/markings.....	8
<b>2</b>	<b>Safety .....</b>	<b>9</b>
	2.1 General.....	9
	2.2 Intended use .....	9
	2.3 Personnel qualification and training.....	9
	2.4 Consequences and risks caused by non-compliance with this manual .....	10
	2.5 Safety awareness .....	10
	2.6 Safety information for the operator/user .....	10
	2.7 Safety information for maintenance, inspection and installation .....	10
	2.8 Unauthorised modes of operation .....	11
	2.9 Explosion protection .....	11
	2.9.1 Marking .....	11
	2.9.2 Temperature limits.....	11
	2.9.3 Monitoring equipment.....	12
	2.9.4 Operating limits .....	12
<b>3</b>	<b>Transport/Temporary Storage/Disposal.....</b>	<b>13</b>
	3.1 Checking the condition upon delivery .....	13
	3.2 Transport.....	13
	3.3 Storage/preservation .....	14
	3.4 Return to supplier.....	14
	3.5 Disposal .....	15
<b>4</b>	<b>Description of the Pump (Set) .....</b>	<b>16</b>
	4.1 General description .....	16
	4.2 Designation.....	16
	4.3 Name plate.....	16
	4.4 Design details.....	17
	4.5 Configuration and function.....	18
	4.6 Noise characteristics .....	19
	4.7 Scope of supply.....	19
	4.8 Dimensions and weights .....	20
<b>5</b>	<b>Installation at Site .....</b>	<b>21</b>
	5.1 Safety regulations.....	21
	5.2 Checks to be carried out prior to installation.....	21
	5.3 Installing the pump set .....	21
	5.3.1 Installation on a foundation .....	22
	5.4 Piping .....	23
	5.4.1 Connecting the piping.....	23
	5.4.2 Permissible forces and moments at the pump nozzles.....	25
	5.4.3 Auxiliary connections.....	26
	5.5 Enclosure/insulation .....	27
	5.6 Checking the coupling alignment .....	27
	5.7 Aligning the pump and motor .....	28
	5.8 Electrical connection .....	29
	5.8.1 Earthing.....	29
	5.8.2 Connecting the motor .....	30

5.9	Checking the direction of rotation.....	30
<b>6</b>	<b>Commissioning/Start-up/Shutdown.....</b>	<b>31</b>
6.1	Commissioning/Start-up.....	31
6.1.1	Prerequisites for commissioning/start-up.....	31
6.1.2	Filling in the lubricant.....	31
6.1.3	Shaft seal.....	33
6.1.4	Priming and venting the pump.....	33
6.1.5	Final check.....	34
6.1.6	Water cooling.....	34
6.1.7	Cooling of the pump.....	34
6.1.8	Cooling of the shaft seal.....	35
6.1.9	Heating.....	35
6.1.10	Heating up/keeping warm the pump (set).....	36
6.1.11	Start-up.....	36
6.1.12	Checking the shaft seal.....	37
6.1.13	Shutdown.....	38
6.2	Operating limits.....	38
6.2.1	Ambient temperature.....	39
6.2.2	Frequency of starts.....	39
6.2.3	Fluid handled.....	39
6.3	Shutdown/storage/preservation.....	40
6.3.1	Measures to be taken for shutdown.....	40
6.4	Returning to service.....	41
<b>7</b>	<b>Servicing/Maintenance.....</b>	<b>42</b>
7.1	Safety regulations.....	42
7.2	Servicing/Inspection.....	43
7.2.1	Supervision of operation.....	43
7.2.2	Inspection work.....	45
7.2.3	Lubrication and lubricant change of rolling element bearings.....	47
7.3	Drainage/cleaning.....	49
7.4	Dismantling the pump set.....	49
7.4.1	General information/Safety regulations.....	49
7.4.2	Preparing the pump set.....	50
7.4.3	Removing the motor.....	50
7.4.4	Removing the back pull-out unit.....	50
7.4.5	Removing the impeller.....	51
7.4.6	Removing the cartridge seal.....	51
7.4.7	Dismantling the bearings.....	52
7.5	Reassembling the pump set.....	52
7.5.1	General information/Safety regulations.....	52
7.5.2	Fitting the bearings.....	53
7.5.3	Fitting the shaft seal.....	55
7.5.4	Fitting the impeller.....	55
7.5.5	Installing the back pull-out unit.....	56
7.5.6	Mounting the motor.....	56
7.6	Tightening torques.....	57
7.6.1	Tightening torques for the pump.....	57
7.6.2	Tightening torques for the shaft nut.....	60
7.7	Spare parts stock.....	60
7.7.1	Ordering spare parts.....	60
7.7.2	Recommended spare parts stock for 2 years' operation to DIN 24296.....	61
7.7.3	Interchangeability of pump components.....	62
<b>8</b>	<b>Trouble-shooting.....</b>	<b>64</b>
<b>9</b>	<b>Related Documents.....</b>	<b>66</b>
9.1	General assembly drawings with list of components.....	66
9.1.1	Bearing brackets B02 to B05.....	66
9.1.2	Bearing brackets B06 and B07.....	68

9.1.3	Design variants.....	70
10	<b>EU Declaration of Conformity .....</b>	<b>73</b>
11	<b>Certificate of Decontamination.....</b>	<b>74</b>
	<b>Index .....</b>	<b>75</b>

## Glossary

### **Back pull-out design**

The complete back pull-out unit can be pulled out without having to remove the pump casing from the piping.

### **Back pull-out unit**

Pump without pump casing; partly completed machinery

### **Certificate of decontamination**

A certificate of decontamination is enclosed by the customer when returning the product to the manufacturer to certify that the product has been properly drained to eliminate any environmental and health hazards arising from components in contact with the fluid handled.

### **Discharge line**

The pipeline which is connected to the discharge nozzle

### **Hydraulic system**

The part of the pump in which the kinetic energy is converted into pressure energy

### **Pool of pumps**

Customers/operators' pumps which are purchased and stored regardless of their later use.

### **Pump**

Machine without drive, additional components or accessories

### **Pump set**

Complete pump set consisting of pump, drive, additional components and accessories

### **Suction lift line/suction head line**

The pipeline which is connected to the suction nozzle

## 1 General

### 1.1 Principles

This operating manual is valid for the type series and variants indicated on the front cover.

The manual describes the proper and safe use of this equipment in all phases of operation.

The name plate indicates the type series and size, the main operating data, the order number and the order item number. The order number and order item number clearly identify the pump set and serve as identification for all further business processes.

In the event of damage, immediately contact your nearest KSB Service centre to maintain the right to claim under warranty.

### 1.2 Installation of partly completed machinery

To install partly completed machinery supplied by KSB refer to the sub-sections under Servicing/Maintenance. (⇒ Section 7.5.5, Page 56)

### 1.3 Target group

This operating manual is aimed at the target group of trained and qualified specialist technical personnel. (⇒ Section 2.3, Page 9)

### 1.4 Other applicable documents

**Table 1:** Overview of other applicable documents

Document	Contents
Data sheet	Description of the technical data of the pump (set)
General arrangement drawing/ outline drawing	Description of mating and installation dimensions for the pump (set), weights
Drawing of auxiliary connections	Description of auxiliary connections
Hydraulic characteristic curve	Characteristic curves showing head, NPSH required, efficiency and power input
General assembly drawing <sup>1)</sup>	Sectional drawing of the pump
Sub-supplier product literature <sup>1)</sup>	Operating manuals and other product literature describing accessories and integrated machinery components
Spare parts lists <sup>1)</sup>	Description of spare parts
Piping layout <sup>1)</sup>	Description of auxiliary piping
List of components <sup>1)</sup>	Description of all pump components
Drawing for assembly <sup>1)</sup>	Sectional drawing of the installed shaft seal

For accessories and/or integrated machinery components observe the relevant manufacturer's product literature.

### 1.5 Symbols

**Table 2:** Symbols used in this manual







Symbol	Description
✓	Conditions which need to be fulfilled before proceeding with the step-by-step instructions
▷	Safety instructions
⇒	Result of an action
⇔	Cross-references

1) If agreed upon in scope of supply

Symbol	Description
1. 2.	Step-by-step instructions
	Note Recommendations and important information on how to handle the product

### 1.6 Key to safety symbols/markings

Table 3: Definition of safety symbols/markings

Symbol	Description
 <b>DANGER</b>	<b>DANGER</b> This signal word indicates a high-risk hazard which, if not avoided, will result in death or serious injury.
 <b>WARNING</b>	<b>WARNING</b> This signal word indicates a medium-risk hazard which, if not avoided, could result in death or serious injury.
<b>CAUTION</b>	<b>CAUTION</b> This signal word indicates a hazard which, if not avoided, could result in damage to the machine and its functions.
	<b>Explosion protection</b> This symbol identifies information about avoiding explosions in potentially explosive atmospheres in accordance with EU Directive 2014/34/EU (ATEX).
	<b>General hazard</b> In conjunction with one of the signal words this symbol indicates a hazard which will or could result in death or serious injury.
	<b>Electrical hazard</b> In conjunction with one of the signal words this symbol indicates a hazard involving electrical voltage and identifies information about protection against electrical voltage.
	<b>Machine damage</b> In conjunction with the signal word CAUTION this symbol indicates a hazard for the machine and its functions.





## 2 Safety

All the information contained in this section refers to hazardous situations.

In addition to the present general safety information the action-related safety information given in the other sections must be observed.

### 2.1 General

This operating manual contains general installation, operating and maintenance instructions that must be observed to ensure safe operation of the system and prevent personal injury and damage to property.

The safety information in all sections of this manual must be complied with.

The operating manual must be read and understood by the responsible specialist personnel/operators prior to installation and commissioning.

The contents of this operating manual must be available to the specialist personnel at the site at all times.

Information attached directly to the product must always be complied with and kept in a perfectly legible condition at all times. This applies to, for example:

- Arrow indicating the direction of rotation
- Markings for connections
- Name plate

The operator is responsible for ensuring compliance with all local regulations not taken into account in this operating manual.

### 2.2 Intended use

- The pump (set) must only be operated in the fields of application and within the use limits specified in the other applicable documents. (⇒ Section 1.4, Page 7)
- Only operate pumps/pump sets which are in perfect technical condition.
- Do not operate the pump (set) in partially assembled condition.
- Only use the pump to handle the fluids described in the data sheet or product literature of the pump model or variant.
- Never operate the pump without the fluid to be handled.
- Observe the minimum flow rates indicated in the data sheet or product literature (to prevent overheating, bearing damage, etc).
- Observe the minimum flow rate and maximum flow rate indicated in the data sheet or product literature (to prevent overheating, mechanical seal damage, cavitation damage, bearing damage, etc).
- Do not throttle the flow rate on the suction side of the pump (to prevent cavitation damage).
- Consult the manufacturer about any use or mode of operation not described in the data sheet or product literature.

### 2.3 Personnel qualification and training

All personnel involved must be fully qualified to transport, install, operate, maintain and inspect the machinery this manual refers to.

The responsibilities, competence and supervision of all personnel involved in transport, installation, operation, maintenance and inspection must be clearly defined by the operator.

Deficits in knowledge must be rectified by means of training and instruction provided by sufficiently trained specialist personnel. If required, the operator can commission the manufacturer/supplier to train the personnel.

Training on the pump (set) must always be supervised by technical specialist personnel.

### **2.4 Consequences and risks caused by non-compliance with this manual**

- Non-compliance with these operating instructions will lead to forfeiture of warranty cover and of any and all rights to claims for damages.
- Non-compliance can, for example, have the following consequences:
  - Hazards to persons due to electrical, thermal, mechanical and chemical effects and explosions
  - Failure of important product functions
  - Failure of prescribed maintenance and servicing practices
  - Hazard to the environment due to leakage of hazardous substances

### **2.5 Safety awareness**

In addition to the safety information contained in this manual and the intended use, the following safety regulations shall be complied with:

- Accident prevention, health regulations and safety regulations
- Explosion protection regulations
- Safety regulations for handling hazardous substances
- Applicable standards, directives and laws

### **2.6 Safety information for the operator/user**

- Fit protective equipment (e.g. contact guards) supplied by the operator for hot, cold or moving parts, and check that the equipment functions properly.
- Do not remove any protective equipment (e.g. contact guards) during operation.
- Provide the personnel with protective equipment and make sure it is used.
- Contain leakages (e.g. at the shaft seal) of hazardous fluids handled (e.g. explosive, toxic, hot) so as to avoid any danger to persons and the environment. Adhere to all relevant laws.
- Eliminate all electrical hazards. (In this respect refer to the applicable national safety regulations and/or regulations issued by the local energy supply companies.)
- If shutting down the pump does not increase potential risk, fit an emergency-stop control device in the immediate vicinity of the pump (set) during pump set installation.

### **2.7 Safety information for maintenance, inspection and installation**

- Modifications or alterations of the pump (set) are only permitted with the manufacturer's prior consent.
- Use only original spare parts or parts/components authorised by the manufacturer. The use of other parts/components can invalidate any liability of the manufacturer for resulting damage.
- The operator ensures that maintenance, inspection and installation is performed by authorised, qualified specialist personnel who are thoroughly familiar with the manual.
- Only carry out work on the pump (set) during standstill of the pump.
- Only perform work on the pump set when it has been disconnected from the power supply (de-energised).
- The pump (set) must have cooled down to ambient temperature.
- Pump pressure must have been released and the pump must have been drained.

- When taking the pump set out of service always adhere to the procedure described in the manual. (⇒ Section 6.1.13, Page 38) (⇒ Section 6.3, Page 40)
- Decontaminate pumps which handle fluids posing a health hazard. (⇒ Section 7.3, Page 49)
- As soon as the work has been completed, re-install and re-activate any safety-relevant devices and protective devices. Before returning the product to service, observe all instructions on commissioning. (⇒ Section 6.1, Page 31)

### 2.8 Unauthorised modes of operation

Never operate the pump (set) outside the limits stated in the data sheet and in this manual.

The warranty relating to the operating reliability and safety of the supplied pump (set) is only valid if the equipment is used in accordance with its intended use. (⇒ Section 2.2, Page 9)

### 2.9 Explosion protection



**Always observe the information on explosion protection given in this section when operating the product in potentially explosive atmospheres.**

Only pumps/pump sets marked as explosion-proof **and** identified as such in the data sheet may be used in potentially explosive atmospheres.

Special conditions apply to the operation of explosion-proof pump sets to EU Directive 2014/34/EU (ATEX).

Especially adhere to the sections in this manual marked with the symbol opposite and the following sections, (⇒ Section 2.9.1, Page 11) to (⇒ Section 2.9.4, Page 12)

The explosion-proof status of the pump set is only assured if the pump set is used in accordance with its intended use.

Never operate the pump set outside the limits stated in the data sheet and on the name plate.

Prevent impermissible modes of operation at all times.

#### 2.9.1 Marking

**Pump** The marking on the pump refers to the pump part only.

Example of such marking:

II 2 G c TX (EN 13463-1) or II 2G Ex h IIC T5-T1 Gb (ISO 80079-36)

Refer to the individual Temperature Limits table for the temperatures permitted for the individual pump variants. (⇒ Section 2.9.2, Page 11)

The pump complies with the requirements of type of protection constructional safety "c" to ISO 80079-37.

**Shaft coupling** An EC manufacturer's declaration is required for the shaft coupling; the shaft coupling must be marked accordingly.

**Motor** The motor must be considered separately.

#### 2.9.2 Temperature limits

In normal pump operation, the highest temperatures are to be expected on the surface of the pump casing, at the shaft seal and in the bearing areas.

The surface temperature at the pump casing corresponds to the temperature of the fluid handled. If the pump is heated in addition, the operator of the system is responsible for observing the specified temperature class and fluid temperature (operating temperature).

The table below lists the temperature classes and the resulting theoretical temperature limits of the fluid handled (a possible temperature rise in the shaft seal area has already been taken into account).

The temperature class specifies the maximum permissible temperature at the surface of the pump set during operation. For the permissible operating temperature of the pump in question refer to the data sheet.

**Table 4:** Temperature limits

Temperature class to EN 13463-1 or ISO 80079-36	Maximum permissible fluid temperature
T1	Maximum 400 °C <sup>2)</sup>
T2	280 °C
T3	185 °C
T4	120 °C
T5	85 °C
T6	Only after consultation with the manufacturer

**Temperature class T5** Based on an ambient temperature of 40 °C and proper maintenance and operation, compliance with temperature class T5 is warranted in the area of the rolling element bearings. If the ambient temperature exceeds 40 °C, contact the manufacturer.

**Temperature class T6** A special design is required to comply with the requirements of temperature class T6 in the bearing area.

Misuse, malfunctions or non-compliance with the instructions may result in substantially higher temperatures.

If the pump is to be operated at a higher temperature, if there is no data sheet or if the pump is part of a pool of pumps, contact KSB for the maximum permissible operating temperature.

### 2.9.3 Monitoring equipment

The pump (set) must only be operated within the limits specified in the data sheet and on the name plate.

If the system operator cannot warrant compliance with these operating limits, appropriate monitoring devices must be used.

Check whether monitoring equipment is required to ensure that the pump set functions properly.

Contact KSB for further information about monitoring equipment.

### 2.9.4 Operating limits

The minimum flows indicated in (⇒ Section 6.2.3.1, Page 39) refer to water and water-like fluids handled. Longer operating periods with these fluids and at the flow rates indicated will not cause an additional increase in the temperatures at the pump surface. However, if the physical properties of the fluids handled are different from water, it is essential to check whether an additional heat build-up may occur and if the minimum flow rate must therefore be increased. The calculation formula in (⇒ Section 6.2.3.1, Page 39) can be used to check whether additional heat build-up may lead to a dangerous temperature increase at the pump surface.

---

2) Depending on the material variant

### 3 Transport/Temporary Storage/Disposal

#### 3.1 Checking the condition upon delivery

1. On transfer of goods, check each packaging unit for damage.
2. In the event of in-transit damage, assess the exact damage, document it and notify KSB or the supplying dealer and the insurer about the damage in writing immediately.

#### 3.2 Transport

	<b>DANGER</b>
	<p><b>The pump (set) could slip out of the suspension arrangement</b>            Danger to life from falling parts!</p> <ul style="list-style-type: none"> <li>▷ Always transport the pump (set) in the specified position.</li> <li>▷ Never attach the suspension arrangement to the free shaft end or the motor eyebolt.</li> <li>▷ Observe the information about weights, centre of gravity and fastening points.</li> <li>▷ Observe the applicable local accident prevention regulations.</li> <li>▷ Use suitable, permitted lifting accessories, e.g. self-tightening lifting tongs.</li> </ul>

To transport the pump/pump set or back pull-out unit suspend it from the lifting tackle as shown.

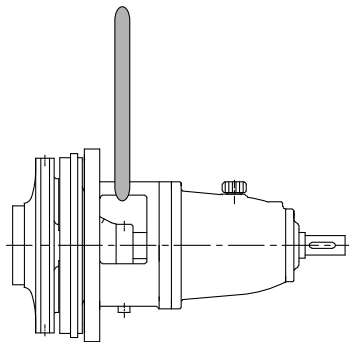

Fig. 1: Transporting the back pull-out unit

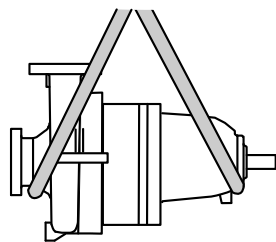

Fig. 2: Transporting the pump

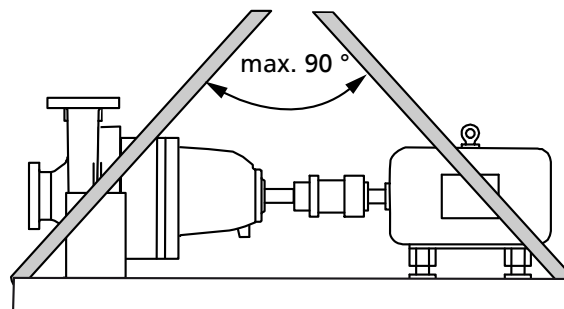

Fig. 3: Transporting the pump set

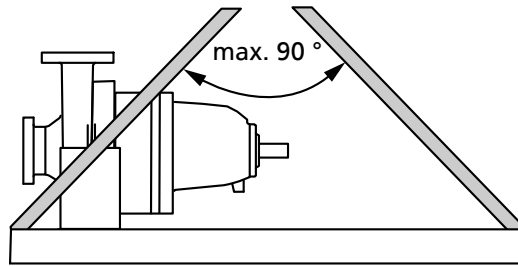

Fig. 4: Transporting the pump on the baseplate

### 3.3 Storage/preservation

If commissioning is to take place some time after delivery, we recommend that the following measures be taken for pump (set) storage.

	<p style="background-color: #FFD700; padding: 5px;"><b>CAUTION</b></p> <p><b>Damage during storage due to humidity, dirt or vermin</b> Corrosion/contamination of the pump (set)!</p> <ul style="list-style-type: none"> <li>▷ For outdoor storage cover the pump (set) or the packaged pump (set) and accessories with waterproof material.</li> </ul>
	<p style="background-color: #FFD700; padding: 5px;"><b>CAUTION</b></p> <p><b>Wet, contaminated or damaged openings and connections</b> Leakage or damage to the pump!</p> <ul style="list-style-type: none"> <li>▷ Clean and cover pump openings and connections as required prior to putting the pump into storage.</li> </ul>

Store the pump (set) in a dry, protected room where the atmospheric humidity is as constant as possible.

Rotate the shaft by hand once a month, e.g. via the motor fan.

If properly stored indoors, the pump set is protected for a maximum of 12 months. New pumps/pump sets are supplied by our factory duly prepared for storage.



For storing a pump (set) which has already been operated, the shutdown measures must be adhered to. (⇒ Section 6.3.1, Page 40)

### 3.4 Return to supplier

1. Drain the pump as per operating instructions. (⇒ Section 7.3, Page 49)
2. Flush and clean the pump, particularly if it has been used for handling noxious, explosive, hot or other hazardous fluids.
3. If the pump has handled fluids whose residues could lead to corrosion damage in the presence of atmospheric humidity or could ignite upon contact with oxygen also neutralise the pump and blow through with anhydrous inert gas to ensure drying.
4. Always complete and enclose a certificate of decontamination when returning the pump.  
Indicate any safety measures and decontamination measures taken.  
(⇒ Section 11, Page 74)

	<p style="background-color: #0070C0; color: white; padding: 5px;"><b>NOTE</b></p> <p>If required, a blank certificate of decontamination can be downloaded from the following web site: <a href="http://www.ksb.com/certificate_of_decontamination">www.ksb.com/certificate_of_decontamination</a></p>
--	--

## 3.5 Disposal

	 <b>WARNING</b>
	<p><b>Fluids handled, consumables and supplies which are hot and/or pose a health hazard</b></p> <p>Hazard to persons and the environment!</p> <ul style="list-style-type: none"><li>▶ Collect and properly dispose of flushing fluid and any fluid residues.</li><li>▶ Wear safety clothing and a protective mask if required.</li><li>▶ Observe all legal regulations on the disposal of fluids posing a health hazard.</li></ul>

1. Dismantle the pump (set).  
Collect greases and other lubricants during dismantling.
2. Separate and sort the pump materials, e.g. by:
  - Metals
  - Plastics
  - Electronic waste
  - Greases and other lubricants
3. Dispose of materials in accordance with local regulations or in another controlled manner.

## 4 Description of the Pump (Set)

### 4.1 General description

- Process pump to API 610

Pump for handling the large variety of petroleum products in refineries as well as in the chemical and petrochemical industry.

### 4.2 Designation

Example: RPH-H-I S1 80-280B

Table 5: Designation key

Code	Description
RPH	Type series
H	Heatable version
I	Version with auxiliary impeller (inducer)
S1	Material variant to API 610
80	Nominal discharge nozzle diameter [mm]
280	Nominal impeller diameter [mm]
B	Special hydraulic system (type B)

### 4.3 Name plate

KSB SE & Co. KGaA Johann-Klein-Straße 9 67227 Frankenthal		CE	
1	Order No.	Year	2018
2	Serial No. 997186942100630001	Type	RPH 100-280
3	Item No. 107-P-102B	Test pressure	7200 kPa
4	Q 110 m <sup>3</sup> /h	H 70,00 m	m 345 kg
5	n 2950	1/min	t 60 °C
6	ρ 0,51	kg/dm <sup>3</sup>	MAWP 4800 kPa @ 85 °C
7	Shaft seal H75VK/85-PTA80		
8	Bearings NU 213C3/2 * 7311BMUA		
Impeller Ø mm		max.	min.
standard	1 st stage	295	230
	2 nd stage	-	-
Mat. No. 01831160		ZN 3826 - 310 EN	

Fig. 5: Name plate (example)

1	Customer order number	2	KSB order number
3	Item number	4	Flow rate
5	Rated speed	6	Density of the fluid handled
7	Shaft seal	8	Bearings
9	Maximum impeller diameter	10	Minimum impeller diameter
11	Impeller diameter when installed	12	Year of construction
13	Type series, size	14	Test pressure
15	Head	16	Weight
17	Application temperature	18	Maximum permissible pressure@temperature



#### 4.4 Design details

##### Design

- Volute casing pump
- Horizontal installation
- Back pull-out design
- Single-stage
- Technical requirements to API 610 [8th edition] and ISO 9905

##### Pump casing

- Volute casing with integrally cast pump feet
- Centreline pump feet
- Single or double volute, depending on the pump size
- Radially split volute casing
- Replaceable casing wear rings (optional for casing material C)
- Axial inlet nozzle, tangential discharge nozzle pointing vertically upwards. (From DN 250 / from impeller diameter 500 / size 200-401: radial discharge nozzle pointing vertically upwards)
- Volute casing with casing wear ring
- Casing cover (with casing wear ring, as required)

##### Optional:

- Casing and casing cover heatable/coolable, depending on size

##### Shaft seal

- Cartridge seal to API 682

##### Impeller type

- Closed radial impeller
- Impeller with impeller wear ring on the suction side (if required also on the discharge side)
- Sealing gap and balancing holes balance axial forces.

##### Optional:

- Inducer to improve the NPSH value

##### Bearings

- Uncooled

##### Optional:

- Cooled bearing bracket

##### Drive-end bearing:

- Fixed bearing
- Paired angular contact ball bearings
- Oil bath lubrication
- **Optional:** oil mist lubrication

##### Pump-end bearing:

- Radial bearing
- Cylindrical roller bearing
- Absorbs radial loads only
- Oil bath lubrication
- **Optional:** oil mist lubrication

Bearing bracket designation Example: B03

Table 6: Bearing bracket designation

Designation	Description
B	Back pull-out bearing bracket
03	Size code (based on dimensions of seal chamber, shaft end and bearings)

Bearings used Table 7: Bearing design

KSB designation	FAG designation	SKF designation
B.MUA	B-MP-UA	BECBM

Table 8: Standard bearing assembly

Bearing bracket	Rolling element bearings	
	Pump end	Motor end
B02	NU211E	2 x 7309B-MUA
B03	NU213E	2 x 7311B-MUA
B05	NU316E	2 x 7315B-MUA
B06	NU324E	2 x 7224B-MUA
B07	NU324E	2 x 7324B-MUA

Table 9: Reinforced bearing assembly (triple bearing assembly)

Bearing bracket	Rolling element bearings	
	Pump end	Motor end
B02	NU211E	3 x 7309B-MUA
B03	NU213E	3 x 7311B-MUA
B05	NU316E	3 x 7315B-MUA
B06	NU324E	3 x 7224B-MUA
B07	NU324E	3 x 7324B-MUA

4.5 Configuration and function

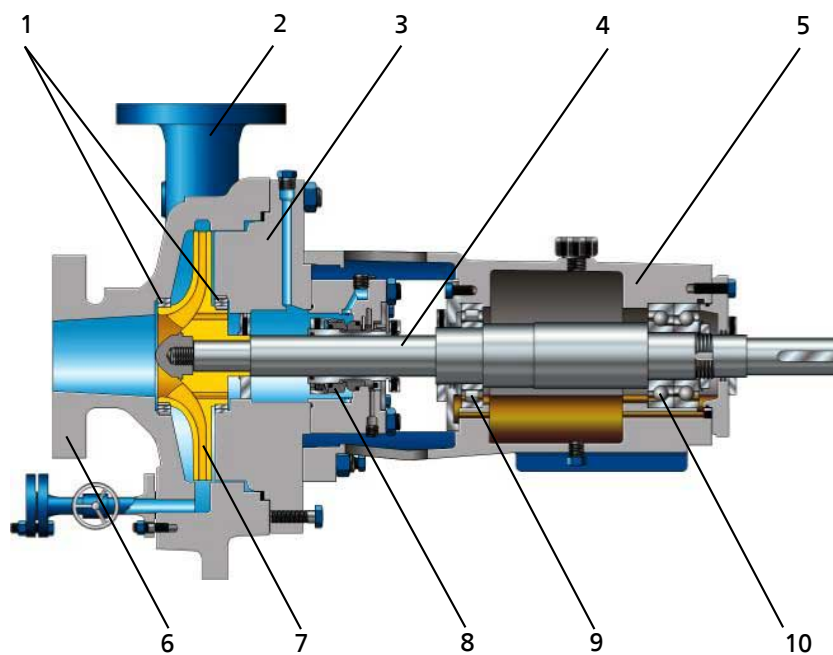

1	Clearance gap	2	Discharge nozzle
3	Casing cover	4	Shaft
5	Bearing bracket	6	Suction nozzle

7	Impeller	8	Shaft seal
9	Rolling element bearing, pump end	10	Rolling element bearing, motor end

**Design** The pump is designed with an axial fluid inlet and a radial or tangential outlet. The hydraulic system runs in its own bearings and is connected to the motor by a shaft coupling.

**Function** The fluid enters the pump axially via the suction nozzle (6) and is accelerated outward by the rotating impeller (7). In the flow passage of the pump casing the kinetic energy of the fluid is converted into pressure energy. The fluid is pumped to the discharge nozzle (2), where it leaves the pump. The clearance gap (1) prevents any fluid from flowing back from the pump casing into the suction nozzle. At the rear side of the impeller, the shaft (4) enters the hydraulic system via the casing cover (3). The shaft passage through the cover is sealed to atmosphere with a shaft seal (8). The shaft runs in rolling element bearings (9 and 10), which are supported by a bearing bracket (5) connected to the casing cover.

**Sealing** The pump is sealed by a standardised mechanical seal.

#### 4.6 Noise characteristics

**Table 10:** Surface sound pressure level  $L_{pA}$ <sup>3)4)5)</sup>

$P_N$	Pump			Pump set		
	960 rpm, 760 rpm	1450 rpm	2900 rpm	960 rpm, 760 rpm	1450 rpm	2900 rpm
[kW]	[dB]	[dB]	[dB]	[dB]	[dB]	[dB]
1,5	52	53	54	56	58	63
2,2	53	55	56	58	60	66
3	55	56	57	60	62	68
4	56	58	59	61	63	69
5,5	58	59	61	62	65	71
7,5	59	61	62	64	66	72
11	61	63	64	65	68	74
15	63	65	66	67	69	75
18,5	64	66	67	68	70	76
22	65	67	68	68	71	77
30	66	68	70	70	72	78
37	67	70	71	70	73	79
45	68	71	72	71	74	80
55	69	72	73	72	74	80
75	71	73	75	73	76	81
90	71	74	76	73	76	82
110	72	75	77	74	77	82
132	73	76	78	75	77	83
160	74	77	79	75	78	84
200	75	78	80	76	79	84
250	-	79	81	-	80	85

#### 4.7 Scope of supply

Depending on the model, the following items are included in the scope of supply:

- Pump

3) Spatial average; as per ISO 3744 and EN 12639; valid for pump operation in the  $Q/Q_{opt} = 0.8 - 1.1$  range and for non-cavitating operation. If noise levels are to be guaranteed: add +3 dB for measuring and constructional tolerance.  
 4) Increase for 60 Hz operation: 3500 rpm +3 dB; 1750 rpm +1 dB; 1160 rpm ±0 dB  
 5) Increase for model with fan: 2900 rpm and 3500 rpm: +3 dB

### **Coupling**

- Rigid multiple-disc clutch with spacer sleeve
- Coupling guard

### **Baseplate**

- Welded baseplate for pump and motor, in torsion-resistant design

### **Special accessories**



- As required

### **4.8 Dimensions and weights**

For dimensions and weights please refer to the general arrangement drawing/outline drawing of the pump/pump set.



## 5 Installation at Site

### 5.1 Safety regulations

	 <b>DANGER</b>
	<p><b>Excessive temperatures in the shaft seal area</b> Explosion hazard!</p> <ul style="list-style-type: none"> <li>▷ Never operate a pump (set) with gland packing in potentially explosive atmospheres.</li> </ul>

### 5.2 Checks to be carried out prior to installation



#### Place of installation



	 <b>WARNING</b>
	<p><b>Installation on mounting surface which is unsecured and cannot support the load</b> Personal injury and damage to property!</p> <ul style="list-style-type: none"> <li>▷ Use a concrete of compressive strength class C12/15 which meets the requirements of exposure class XC1 to EN 206-1.</li> <li>▷ The mounting surface must be set, flat, and level.</li> <li>▷ Observe the weights indicated.</li> </ul>

1. Check the structural requirements.  
All structural work required must have been prepared in accordance with the dimensions stated in the outline drawing/general arrangement drawing.

### 5.3 Installing the pump set

Always install the pump set in horizontal position.

	 <b>DANGER</b>
	<p><b>Excessive temperatures due to improper installation</b> Explosion hazard!</p> <ul style="list-style-type: none"> <li>▷ Install the pump in a horizontal position to ensure self-venting of the pump.</li> </ul>

	 <b>DANGER</b>
	<p><b>Static charging due to insufficient potential equalisation</b> Explosion hazard!</p> <ul style="list-style-type: none"> <li>▷ Make sure that the connection between pump and baseplate is electrically conductive.</li> </ul>

5.3.1 Installation on a foundation

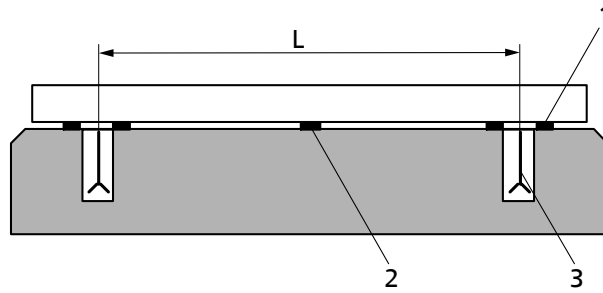

Fig. 6: Fitting the shims



L	Bolt-to-bolt distance	1	Shim
2	Shim if (L) > 800 mm	3	Foundation bolt

- ✓ The foundation has the required strength and characteristics.
  - ✓ The foundation has been prepared in accordance with the dimensions given in the outline drawing/general arrangement drawing.
1. Position the pump set on the foundation and level it with the help of a spirit level placed on the shaft and discharge nozzle.  
Permissible deviation: 0.2 mm/m
  2. Use shims (1) for height compensation, if necessary.  
Always fit shims, if any, immediately to the left and right of the foundation bolts (3) between the baseplate/foundation frame and the foundation.  
For a bolt-to-bolt distance (L) > 800 mm fit additional shims (2) halfway between the bolt holes.  
All shims must lie perfectly flush.
  3. Insert the foundation bolts (3) into the holes provided.
  4. Use concrete to set the foundation bolts (3) into the foundation.
  5. Wait until the concrete has set firmly, then level the baseplate.
  6. Tighten the foundation bolts (3) evenly and firmly.
  7. Grout the baseplate using low-shrinkage concrete with a standard particle size and a water/cement ratio of  $\leq 0.5$ .  
Produce flowability with the help of a solvent.  
Perform secondary treatment of the concrete to EN 206.

	<b>NOTE</b>
	For low-noise operation the pump set can be mounted on vibration dampers upon confirmation by the manufacturer. In this case, only fasten the flexible elements at the baseplate after the piping has been connected.
	<b>NOTE</b>
	Expansion joints can be fitted between the pump and the suction/discharge line.

## 5.4 Piping

### 5.4.1 Connecting the piping

	<p><b>⚠ DANGER</b></p> <p><b>Impermissible loads acting on the pump nozzles</b>          Danger to life from escaping hot, toxic, corrosive or flammable fluids!</p> <ul style="list-style-type: none"> <li>▷ Do not use the pump as an anchorage point for the piping.</li> <li>▷ Anchor the pipes in close proximity to the pump and connect them properly without transmitting any stresses or strains.</li> <li>▷ Observe the permissible forces and moments at the pump nozzles. (⇒ Section 5.4.2, Page 25)</li> <li>▷ Take appropriate measures to compensate for thermal expansion of the piping.</li> </ul>
	<p><b>CAUTION</b></p> <p><b>Incorrect earthing during welding work at the piping</b>          Destruction of rolling element bearings (pitting effect)!</p> <ul style="list-style-type: none"> <li>▷ Never earth the electric welding equipment on the pump or baseplate.</li> <li>▷ Prevent current flowing through the rolling element bearings.</li> </ul>
	<p><b>NOTE</b></p> <p>Installing check and shut-off elements in the system is recommended, depending on the type of plant and pump. However, such elements must not obstruct proper drainage or hinder disassembly of the pump.</p>

- ✓ Suction lift lines have been laid with a rising slope, suction head lines with a downward slope towards the pump.
- ✓ A flow stabilisation section having a length equivalent to at least twice the diameter of the suction flange has been provided upstream of the suction flange.
- ✓ The nominal diameters of the pipelines are at least equal to the nominal diameters of the pump nozzles.
- ✓ Adapters to larger diameters have a diffuser angle of approximately 8° to prevent excessive pressure losses.
- ✓ The pipelines have been anchored in close proximity to the pump and connected without transmitting any stresses or strains.

	<p><b>CAUTION</b></p> <p><b>Welding beads, scale and other impurities in the piping</b>          Damage to the pump!</p> <ul style="list-style-type: none"> <li>▷ Remove any impurities from the piping.</li> <li>▷ If necessary, install a filter.</li> <li>▷ Observe the information in (⇒ Section 7.2.2.3, Page 47) .</li> </ul>
---	---

1. Thoroughly clean, flush and blow through all vessels, pipelines and connections (especially of new installations).
2. Before installing the pump in the piping, remove the flange covers on the suction and discharge nozzles of the pump.
3. Check that the inside of the pump is free from any foreign objects. Remove any foreign objects.

4. If required, install a filter in the piping (see figure: Filter in the piping).

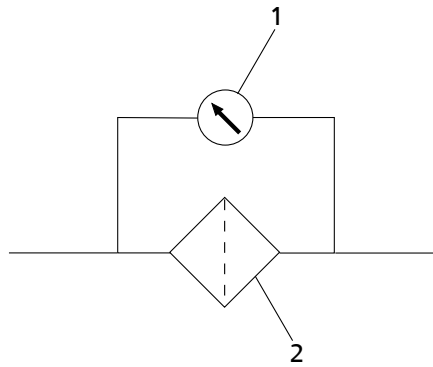

**Fig. 7: Filter in the piping**

1	Differential pressure gauge	2	Filter
---	-----------------------------	---	--------

	<p><b>NOTE</b></p>
<p>Use a filter with laid-in wire mesh (mesh width 0.5 mm, wire diameter 0.25 mm) of corrosion-resistant material. Use a filter with a filter area three times the cross-section of the piping. Conical filters have proved suitable.</p>	

5. Connect the pump nozzles to the piping.

	<p><b>CAUTION</b></p>
<p><b>Aggressive flushing liquid and pickling agent</b> Damage to the pump!</p> <ul style="list-style-type: none"> <li>▷ Match the cleaning operation mode and duration of flushing and pickling to the casing materials and seal materials used.</li> </ul>	



5.4.2 Permissible forces and moments at the pump nozzles

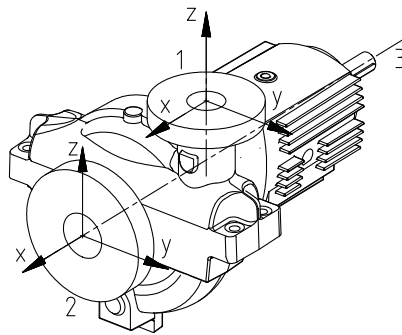

Fig. 8: Coordinate system of forces and moments

1	Discharge nozzle	2	Suction nozzle
3	Shaft centreline		

The pump casings are designed to withstand twice the piping forces and piping moments required by API 610.



For higher forces and moments contact the manufacturer.

Table 11: Forces and moments at the pump nozzles



Size	Suction nozzle								Discharge nozzle							
	Forces				Moments				Forces				Moments			
	[N]				[Nm]				[N]				[Nm]			
	F <sub>x</sub>	F <sub>y</sub>	F <sub>z</sub>	F <sub>res</sub>	M <sub>x</sub>	M <sub>y</sub>	M <sub>z</sub>	M <sub>res</sub>	F <sub>x</sub>	F <sub>y</sub>	F <sub>z</sub>	F <sub>res</sub>	M <sub>x</sub>	M <sub>y</sub>	M <sub>z</sub>	M <sub>res</sub>
25-180	1780	1420	1160	2560	920	460	700	1240	1420	1160	1780	2560	920	460	700	1240
25-230	1780	1420	1160	2560	920	460	700	1240	1420	1160	1780	2560	920	460	700	1240
40-180	1780	1420	1160	2560	920	460	700	1240	1420	1160	1780	2560	920	460	700	1240
40-230	1780	1420	1160	2560	920	460	700	1240	1420	1160	1780	2560	920	460	700	1240
40-280	1780	1420	1160	2560	920	460	700	1240	1420	1160	1780	2560	920	460	700	1240
40-181	1780	1420	1160	2560	920	460	700	1240	1420	1160	1780	2560	920	460	700	1240
40-231	1780	1420	1160	2560	920	460	700	1240	1420	1160	1780	2560	920	460	700	1240
40-281	1780	1420	1160	2560	920	460	700	1240	1420	1160	1780	2560	920	460	700	1240
40-361	1780	1420	1160	2560	920	460	700	1240	1420	1160	1780	2560	920	460	700	1240
50-180	2660	2140	1780	3860	1900	940	1440	2560	1420	1160	1780	2560	920	460	700	1240
50-230	2660	2140	1780	3860	1900	940	1440	2560	1420	1160	1780	2560	920	460	700	1240
50-280	2660	2140	1780	3860	1900	940	1440	2560	1420	1160	1780	2560	920	460	700	1240
50-360	2660	2140	1780	3860	1900	940	1440	2560	1420	1160	1780	2560	920	460	700	1240
50-450	2660	2140	1780	3860	1900	940	1440	2560	1420	1160	1780	2560	920	460	700	1240
80-180	3560	2840	2320	5120	2660	1360	2000	3600	2140	1780	2660	3860	1900	940	1440	2560
80-230	3560	2840	2320	5120	2660	1360	2000	3600	2140	1780	2660	3860	1900	940	1440	2560
80-280	3560	2840	2320	5120	2660	1360	2000	3600	2140	1780	2660	3860	1900	940	1440	2560
80-360	3560	2840	2320	5120	2660	1360	2000	3600	2140	1780	2660	3860	1900	940	1440	2560
80-450	3560	2840	2320	5120	2660	1360	2000	3600	2140	1780	2660	3860	1900	940	1440	2560
100-180	6220	4980	4100	8960	4600	2360	3520	6260	2840	2320	3560	5120	2660	1360	2000	3600
100-230	6220	4980	4100	8960	4600	2360	3520	6260	2840	2320	3560	5120	2660	1360	2000	3600
100-280	6220	4980	4100	8960	4600	2360	3520	6260	2840	2320	3560	5120	2660	1360	2000	3600
100-360	6220	4980	4100	8960	4600	2360	3520	6260	2840	2320	3560	5120	2660	1360	2000	3600
100-450	6220	4980	4100	8960	4600	2360	3520	6260	2840	2320	3560	5120	2660	1360	2000	3600
150-230	9780	7560	6220	13840	7060	3520	5160	9420	4980	4100	6220	8960	4600	2360	3520	6260
150-280	9780	7560	6220	13840	7060	3520	5160	9420	4980	4100	6220	8960	4600	2360	3520	6260
150-360	9780	7560	6220	13840	7060	3520	5160	9420	4980	4100	6220	8960	4600	2360	3520	6260
150-450	9780	7560	6220	13840	7060	3520	5160	9420	4980	4100	6220	8960	4600	2360	3520	6260
150-501	9780	7560	6220	13840	7060	3520	5160	9420	4980	4100	6220	8960	4600	2360	3520	6260
150-630	9780	7560	6220	13840	7060	3520	5160	9420	4980	4100	6220	8960	4600	2360	3520	6260

Size	Suction nozzle								Discharge nozzle							
	Forces				Moments				Forces				Moments			
	[N]				[Nm]				[N]				[Nm]			
	F <sub>x</sub>	F <sub>y</sub>	F <sub>z</sub>	F <sub>res</sub>	M <sub>x</sub>	M <sub>y</sub>	M <sub>z</sub>	M <sub>res</sub>	F <sub>x</sub>	F <sub>y</sub>	F <sub>z</sub>	F <sub>res</sub>	M <sub>x</sub>	M <sub>y</sub>	M <sub>z</sub>	M <sub>res</sub>
200-280	13340	10680	8900	19260	10040	4880	7600	13500	7560	6220	9780	13840	7060	3520	5160	9420
200-360	13340	10680	8900	19260	10040	4880	7600	13500	7560	6220	9780	13840	7060	3520	5160	9420
200-401	13340	10680	8900	19260	10040	4880	7600	13500	7560	6220	9780	13840	7060	3520	5160	9420
200-450	13340	10680	8900	19260	10040	4880	7600	13500	7560	6220	9780	13840	7060	3520	5160	9420
200-501	13340	10680	8900	19260	10040	4880	7600	13500	7560	6220	9780	13840	7060	3520	5160	9420
200-670	13340	10680	8900	19260	10040	4880	7600	13500	7560	6220	9780	13840	7060	3520	5160	9420
250-401	16000	13340	10680	23400	12200	5960	9220	16420	10680	8900	13340	19260	10040	4880	7600	13500
250-501	16000	13340	10680	23400	12200	5960	9220	16420	10680	8900	13340	19260	10040	4880	7600	13500
250-630	16000	13340	10680	23400	12200	5960	9220	16420	10680	8900	13340	19260	10040	4880	7600	13500
250-710	16000	13340	10680	23400	12200	5960	9220	16420	10680	8900	13340	19260	10040	4880	7600	13500
300-400	17800	14240	11560	25560	12740	6240	9500	17080	13340	10680	16000	23400	12200	5960	9220	16420
300-500	17800	14240	11560	25560	12740	6240	9500	17080	13340	10680	16000	23400	12200	5960	9220	16420
300-630	17800	14240	11560	25560	12740	6240	9500	17080	13340	10680	16000	23400	12200	5960	9220	16420
350-400	17800	14240	11560	25560	12740	6240	9500	17080	14240	11560	17800	25560	12740	6240	9500	17080
350-500	17800	14240	11560	25560	12740	6240	9500	17080	14240	11560	17800	25560	12740	6240	9500	17080
350-650	20460	16900	13340	29700	14640	7340	10840	19640	14240	11560	17800	25560	12740	6240	9500	17080
350-710	20460	16900	13340	29700	14640	7340	10840	19640	14240	11560	17800	25560	12740	6240	9500	17080
400-504	20460	16900	13340	29700	14640	7340	10840	19640	16900	13340	20460	29700	14640	7340	10840	19640
400-506	20460	16900	13340	29700	14640	7340	10840	19640	16900	13340	20460	29700	14640	7340	10840	19640
400-710	20460	16900	13340	29700	14640	7340	10840	19640	16900	13340	20460	29700	14640	7340	10840	19640



5.4.3 Auxiliary connections

	<p><b>⚠ DANGER</b></p>
	<p><b>Risk of potentially explosive atmosphere by mixing of incompatible fluids in the auxiliary piping</b></p> <p>Risk of burns!</p> <p>Explosion hazard!</p> <ul style="list-style-type: none"> <li>▷ Make sure that the barrier fluid or quench liquid are compatible with the fluid handled.</li> </ul>
	<p><b>⚠ WARNING</b></p>
	<p><b>Failure to use or incorrect use of auxiliary connections (e.g. barrier fluid, flushing liquid, etc.)</b></p> <p>Risk of injury from escaping fluid!</p> <p>Risk of burns!</p> <p>Malfunction of the pump!</p> <ul style="list-style-type: none"> <li>▷ Refer to the general arrangement drawing, the piping layout and pump markings (if any) for the quantity, dimensions and locations of auxiliary connections.</li> <li>▷ Use the auxiliary connections provided.</li> </ul>

### 5.5 Enclosure/insulation

	<p><b>⚠ DANGER</b></p> <p><b>Risk of potentially explosive atmosphere due to insufficient venting</b> Explosion hazard!</p> <ul style="list-style-type: none"> <li>▷ Make sure the space between the casing cover/discharge cover and the bearing cover is sufficiently vented.</li> <li>▷ Never close or cover the perforation of the bearing bracket guards (e.g. by insulation).</li> </ul>
	<p><b>⚠ WARNING</b></p> <p><b>The volute casing and casing/discharge cover take on the same temperature as the fluid handled</b> Risk of burns!</p> <ul style="list-style-type: none"> <li>▷ Insulate the volute casing.</li> <li>▷ Fit protective equipment.</li> </ul>
	<p><b>CAUTION</b></p> <p><b>Heat build-up in the bearing bracket</b> Damage to the bearing!</p> <ul style="list-style-type: none"> <li>▷ Never insulate the casing cover and the bearing bracket.</li> </ul>

### 5.6 Checking the coupling alignment

 	<p><b>⚠ DANGER</b></p> <p><b>Inadmissible temperatures at the coupling or bearings due to misalignment of the coupling</b> Explosion hazard! Risk of burns!</p> <ul style="list-style-type: none"> <li>▷ Make sure that the coupling is correctly aligned at all times.</li> </ul>
	<p><b>CAUTION</b></p> <p><b>Misalignment of pump and motor shafts</b> Damage to pump, motor and coupling!</p> <ul style="list-style-type: none"> <li>▷ Always check the coupling after the pump has been installed and connected to the piping.</li> <li>▷ Also check the coupling of pump sets supplied with pump and motor mounted on the same baseplate.</li> </ul>

Checking the coupling alignment with a dial gauge

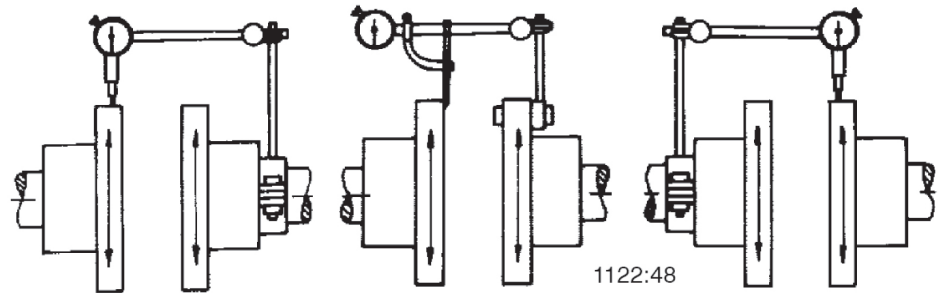

Fig. 9: Checking the spacer-type coupling with a dial gauge

1. Mark the installation position of the coupling by dotting marks (balance condition).
2. Remove the coupling spacer.

	<b>NOTE</b>
<p>While the pump's coupling is disengaged, also check the direction of rotation. (⇒ Section 5.9, Page 30)</p>	

3. Check the alignment of the coupling halves with a dial gauge (see drawing "Checking the spacer-type coupling with a dial gauge").  
 The maximum admissible run-out of the coupling face (axial) equals 0.1 mm.  
 The maximum admissible radial deviation, measured over the complete circumference, equals 0.2 mm.

Checking the coupling alignment with a laser tool

Coupling alignment may also be checked with a laser tool. Observe the documentation provided by the manufacturer of the measuring instrument.

5.7 Aligning the pump and motor

After having installed the pump set and connected the piping, check the coupling alignment and, if required, re-align the pump set (with the motor).

Any differences in shaft centre height between the pump and the motor are compensated by means of shims.

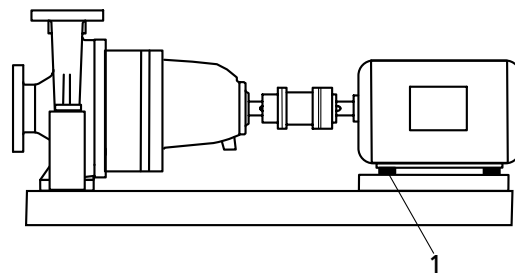

Fig. 10: Pump set with shim

1	Shim
---	------

- ✓ The coupling guard and its footboard, if any, have been removed.

  1. Check the coupling alignment.
  2. Loosen the hexagon head bolts at the motor.
  3. Insert shims underneath the motor feet until the difference in shaft centreline height has been compensated.
  4. Re-tighten the hexagon head bolts.
  5. Check proper functioning of coupling/shaft.  
 Check that coupling/shaft can easily be rotated by hand.

	<p><b>⚠ WARNING</b></p>
	<p><b>Unprotected rotating coupling</b> Risk of injury by rotating shafts!</p> <ul style="list-style-type: none"> <li>▷ Always operate the pump set with a coupling guard. If the customer specifically requests not to include a coupling guard in KSB's delivery, then the operator must supply one!</li> <li>▷ Observe all relevant regulations for selecting a coupling guard.</li> </ul>

6. Fit the coupling guard and its footboard, if any.
7. Check the distance between coupling and coupling guard.  
The coupling guard must not touch the coupling.

	<p><b>⚠ DANGER</b></p>
	<p><b>Risk of ignition by frictional sparks</b> Explosion hazard!!</p> <ul style="list-style-type: none"> <li>▷ Choose a coupling guard material that is non-sparking in the event of mechanical contact.</li> </ul>

**5.8 Electrical connection**

	<p><b>⚠ DANGER</b></p>
	<p><b>Electrical connection work by unqualified personnel</b> Risk of fatal injury due to electric shock!</p> <ul style="list-style-type: none"> <li>▷ Always have the electrical connections installed by a trained and qualified electrician.</li> <li>▷ Observe regulations IEC 60364 and, for explosion-proof models, EN 60079.</li> </ul>

	<p><b>⚠ WARNING</b></p>
	<p><b>Incorrect connection to the mains</b> Damage to the mains network, short circuit!</p> <ul style="list-style-type: none"> <li>▷ Observe the technical specifications of the local energy supply companies.</li> </ul>

1. Check the available mains voltage against the data on the motor name plate.
2. Select an appropriate starting method.

	<p><b>NOTE</b></p>
	<p>A motor protection device is recommended.</p>

**5.8.1 Earthing**

  	<p><b>⚠ DANGER</b></p>
	<p><b>Electrostatic charging</b> Explosion hazard! Damage to the pump set!</p> <ul style="list-style-type: none"> <li>▷ Connect the PE conductor to the earthing terminal provided.</li> <li>▷ Provide for potential equalisation between the pump set and foundation.</li> </ul>

5.8.2 Connecting the motor

	<b>NOTE</b>
	<p>In compliance with IEC 60034-8, three-phase motors are always wired for clockwise rotation (looking at the motor shaft stub). The pump's direction of rotation is indicated by an arrow on the pump.</p>

1. Match the motor's direction of rotation to that of the pump.
2. Observe the manufacturer's product literature supplied with the motor.

5.9 Checking the direction of rotation

	<b>⚠ DANGER</b>
	<p><b>Temperature increase resulting from contact between rotating and stationary components</b> Explosion hazard! Damage to the pump set!</p> <ul style="list-style-type: none"> <li>▷ Never check the direction of rotation by starting up the unfilled pump set.</li> <li>▷ Separate the pump from the motor to check the direction of rotation.</li> </ul>

	<b>⚠ WARNING</b>
	<p><b>Hands inside the pump casing</b> Risk of injuries, damage to the pump!</p> <ul style="list-style-type: none"> <li>▷ Always disconnect the pump set from the power supply and secure it against unintentional start-up before inserting your hands or other objects into the pump.</li> </ul>

	<b>CAUTION</b>
	<p><b>Incorrect direction of rotation of model with auxiliary impeller (inducer)</b> Damage to the pump!</p> <ul style="list-style-type: none"> <li>▷ Separate the pump from the motor to check the direction of rotation.</li> </ul>

	<b>CAUTION</b>
	<p><b>Drive and pump running in the wrong direction of rotation</b> Damage to the pump!</p> <ul style="list-style-type: none"> <li>▷ Refer to the arrow indicating the direction of rotation on the pump.</li> <li>▷ Check the direction of rotation. If required, check the electrical connection and correct the direction of rotation.</li> </ul>

The correct direction of rotation of motor and pump is in clock-wise direction (seen from the motor end).

1. Start the pump set and stop it again immediately to determine the motor's direction of rotation.
2. Check the direction of rotation.  
The motor's direction of rotation must match the arrow indicating the direction of rotation on the pump.
3. If the direction of rotation is incorrect, check the connection of the motor and the switchgear, if any.

## 6 Commissioning/Start-up/Shutdown

### 6.1 Commissioning/Start-up

#### 6.1.1 Prerequisites for commissioning/start-up

Before commissioning/starting up the pump set, make sure that the following conditions are met:

- The pump set has been mechanically connected as specified.
- The pump set has been properly connected to the power supply and is equipped with all protection devices. (⇒ Section 5.8, Page 29)
- The pump has been primed with the fluid to be handled. The pump has been vented. (⇒ Section 6.1.4, Page 33)
- The direction of rotation has been checked. (⇒ Section 5.9, Page 30)
- All auxiliary connections required are connected and operational.
- The lubricants have been checked.
- After prolonged shutdown of the pump (set), the activities required for returning the equipment to service have been carried out. (⇒ Section 6.4, Page 41)

#### 6.1.2 Filling in the lubricant

**Oil-lubricated bearings** Fill the bearing bracket with lubricating oil.

- Oil quality (⇒ Section 7.2.3.1.2, Page 47)
- Oil quantity (⇒ Section 7.2.3.1.3, Page 48)

	<b>NOTE</b>
	<p>On uncooled bearing brackets, first remove the reservoir of the constant level oiler. Then screw in the connection elbow separately.</p>

#### Filling the constant level oiler with lubricating oil (oil bath lubricated bearings only)

- ✓ The constant level oiler is screwed into the upper tapping hole of the bearing bracket.

	<b>NOTE</b>
	<p>If no constant level oiler is provided on the bearing bracket, the oil level can be read in the middle of the oil level gauge arranged at the side of the bearing bracket.</p>

	<b>CAUTION</b>
	<p><b>Insufficient quantity of lubricating oil in the reservoir of the constant level oiler</b>            Damage to the bearings!</p> <ul style="list-style-type: none"> <li>▸ Regularly check the oil level.</li> <li>▸ Always fill the oil reservoir completely.</li> <li>▸ Keep the oil reservoir properly filled at all times.</li> </ul>

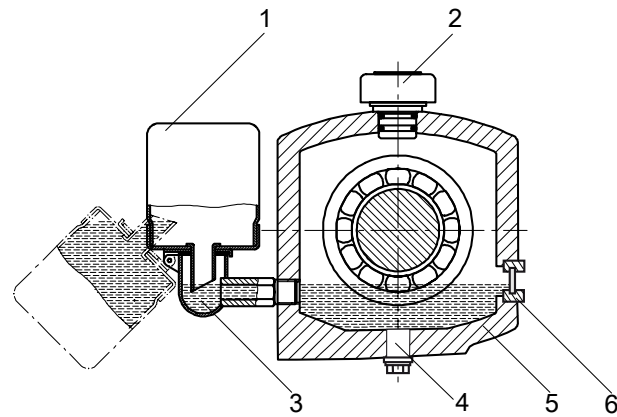

**Fig. 11:** Bearing bracket with constant level oiler

1	Constant level oiler	2	Vent plug
3	Connection elbow of the constant level oiler	4	Screw plug
5	Bearing bracket	6	Oil level sight glass

1. Remove the protective cage.
2. Unscrew the vent plug (2).
3. Hinge down the reservoir of the constant level oiler (1) from the bearing bracket (5) and hold it in this position.
4. Fill in oil through the hole for the vent plug until the oil reaches the connection elbow of the constant level oiler (3).
5. Completely fill the reservoir of the constant level oiler (1).
6. Snap the constant level oiler (1) back into its operating position.
7. Screw the vent plug (2) back in.
8. Fit the protective cage.
9. After approximately 5 minutes, check the oil level in the glass reservoir of the constant level oiler (1).  
The oil reservoir must be properly filled at all times to provide a constant oil level. Repeat steps 1 - 8, if necessary.
10. To check the function of the constant level oiler (1), slowly drain some oil via the screw plug (4) until air bubbles can be seen in the oil reservoir.



**NOTE**

An excessively high oil level can lead to a temperature rise and to leakage of the fluid handled or oil.



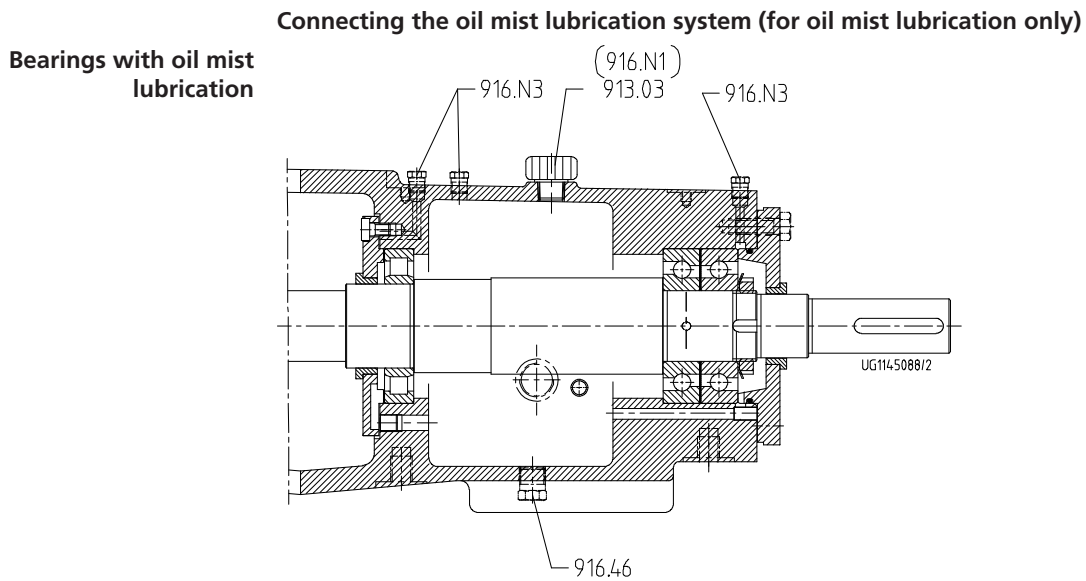

**Fig. 12: Oil mist lubrication**

- ✓ Always observe the instructions of the lubricating system manufacturer (especially on dosing and oil quantity).
- 1. Remove plugs 916.N3.
- 2. Connect the lines of the oil mist lubrication system.
- 3. Remove drain plug 916.46.
- 4. Connect the drain line (returning the oil back into the oil mist system).
- 5. Screw in plug 916.N1.

	<b>NOTE</b>
	Plug 916.N1 replaces vent plug 913.03.

**6.1.3 Shaft seal**

Shaft seals are fitted prior to delivery. Observe the instructions on dismantling (⇒ Section 7.4.6, Page 51) or assembly (⇒ Section 7.5.3, Page 55) .

**Reservoir of non-pressurised external fluid** If applicable, fill the reservoir of non-pressurised external fluid in accordance with the general arrangement drawing.

**Double mechanical seal** Prior to starting up the pump, apply barrier pressure as specified in the general arrangement drawing.

**External liquid feed** Apply the quantities and pressures specified in the data sheet and the general arrangement drawing.

**6.1.4 Priming and venting the pump**

	<b>⚠ DANGER</b>
	<p><b>Risk of potentially explosive atmosphere by mixing of incompatible fluids in the auxiliary piping</b></p> <p>Risk of burns!</p> <p>Explosion hazard!</p> <ul style="list-style-type: none"> <li>▷ Make sure that the barrier fluid or quench liquid are compatible with the fluid handled.</li> </ul>

	<p><b>⚠ DANGER</b></p>
<p><b>Risk of potentially explosive atmosphere inside the pump</b> Explosion hazard!</p> <ul style="list-style-type: none"> <li>▷ The pump internals in contact with the fluid to be handled, including the seal chamber and auxiliary systems must be filled with the fluid to be handled at all times.</li> <li>▷ Provide sufficient inlet pressure.</li> <li>▷ Provide an appropriate monitoring system.</li> </ul>	

	<p><b>⚠ DANGER</b></p>
<p><b>Shaft seal failure caused by insufficient lubrication</b> Hot or toxic fluid could escape! Damage to the pump!</p> <ul style="list-style-type: none"> <li>▷ Before starting up the pump set, vent the pump and suction line and prime both with the fluid to be handled.</li> </ul>	

1. Vent the pump and suction line and prime both with the fluid to be handled.
2. Fully open the shut-off element in the suction line.
3. Fully open all auxiliary connections (barrier fluid, flushing liquid, etc).

**6.1.5 Final check**

1. Remove the coupling guard and its footboard, if any.
2. Check the coupling alignment; re-align the coupling, if required.
3. Check proper functioning of coupling/shaft.  
Check that coupling/shaft can be easily rotated by hand.
4. Fit the coupling guard and its footboard, if any.
5. Check the distance between coupling and coupling guard.  
The coupling guard must not touch the coupling.

**6.1.6 Water cooling**

	<p><b>CAUTION</b></p>
<p><b>Deposit-forming, aggressive cooling water</b> Damage to the pump!</p> <ul style="list-style-type: none"> <li>▷ Observe the cooling water quality.</li> </ul>	

Observe the following quality data of the cooling water:

- Not deposit-forming
- Not aggressive
- Free from suspended solids
- Hardness on average 5 °dH (~1 mmol/l)
- pH > 8
- Conditioned and neutral with regard to mechanical corrosion
- Inlet temperature  $t_{in}$ =10 to 30 °C  
Outlet temperature  $t_{out}$ = 45 °C max.

**6.1.7 Cooling of the pump**

The casing cover, the bearing bracket and the casing support on the baseplate can be cooled.

Observe the following quality data of the cooling water:

- Maximum permissible cooling liquid pressure: 10 bar
- Maximum permissible cooling liquid test pressure: 15 bar
- Observe the specified cooling liquid quantity.

**6.1.8 Cooling of the shaft seal**

	CAUTION
	<p><b>Vaporisation pressure of fluid handled higher than atmospheric pressure</b>                  Damage to the shaft seal/pump!</p> <ul style="list-style-type: none"> <li>▷ Cool the shaft seal.</li> <li>▷ Provide sufficient quantities of cooling liquid (see table).</li> </ul>
	NOTE
	<p>The vaporisation pressure varies depending on the fluid handled, the system pressure and the material of the shaft seal (e.g. hot water).</p>

**Table 12:** Cooling liquid quantities:

	Fluid temperature [°C]	Cooling liquid quantities [m <sup>3</sup> /h] <sup>6)</sup>
Casing cover	< 250	0,3
	< 400	0,6
Bearing bracket	200 <sup>7)</sup> /250 to 315 <sup>8)</sup>	0.2
	> 315 <sup>9)</sup>	
Support on baseplate	> 250	0.2

**6.1.8.1 Cooling of the heat exchanger**

For mechanical seals with product circulation observe the following for the heat exchanger:

**Table 13:** Cooling liquid quantity depending on the bearing bracket

At speed n [rpm]	Cooling liquid [m <sup>3</sup> /h]				
	Bearing bracket				
	B02	B03	B05	B06	B07
1750/1450	0.35	0.5	0.6	0.8	0.8
3500/2900	1.2	1.2	1.8	-	-

**6.1.9 Heating**

	<b>DANGER</b>
	<p><b>Excessive surface temperature</b>                  Explosion hazard!                  Risk of burns!</p> <ul style="list-style-type: none"> <li>▷ Observe the permissible temperature classes. (⇒ Section 2.9.2, Page 11)</li> </ul>

6) The cooling liquid quantities indicated are based on Δt = max. 15 °C.  
 7) For n = 3500 rpm and n = 2900 rpm in conjunction with triple bearing assembly. In all other cases from 250 °C!  
 8) Water cooling or fan wheel  
 9) Water cooling (and fan wheel optional)

	<b>CAUTION</b>
	<p><b>Time for warming up the pump too short</b>            Damage to the pump!</p> <ul style="list-style-type: none"> <li>▷ Check that the pump is sufficiently warmed up throughout.</li> </ul>

The casing cover can be heated with hot water or steam. Observe the following data for the heating medium:

- Maximum permissible temperature  $t = 150\text{ °C}$
- Maximum permissible pressure  $p = 10\text{ bar}$

	<b>CAUTION</b>
	<p><b>Lack of heating medium</b>            Damage to the pump!</p> <ul style="list-style-type: none"> <li>▷ Provide sufficient quantities of a suitable heating medium.</li> </ul>

**6.1.10 Heating up/keeping warm the pump (set)**

	<b>CAUTION</b>
	<p><b>Pump blockage</b>            Damage to the pump!</p> <ul style="list-style-type: none"> <li>▷ Prior to pump start-up, heat up the pump as described in the manual.</li> </ul>

Observe the following when heating up the pump (set) and keeping it warm:



- Make sure that the temperature is increased continuously.
- Max. heating speed:  $10\text{ °C/min}$  ( $10\text{ K/min}$ )

**Fluid temperatures above 150 °C** When the pump is used for handling fluids at temperatures above  $150\text{ °C}$  make sure that the pump has been heated throughout before starting it up.

**Temperature difference** The temperature difference between the pump's surface and the fluid handled must not exceed  $100\text{ °C}$  ( $100\text{ K}$ ) when the pump is started up.

**6.1.11 Start-up**

	<b>⚠ DANGER</b>
	<p><b>Non-compliance with the permissible pressure and temperature limits if the pump is operated with the suction and/or discharge line closed.</b>            Explosion hazard!            Hot or toxic fluids escaping!</p> <ul style="list-style-type: none"> <li>▷ Never operate the pump with the shut-off elements in the suction line and/or discharge line closed.</li> <li>▷ Only start up the pump set with the discharge-side shut-off element slightly or fully open.</li> </ul>

 	<p><b>⚠ DANGER</b></p>
	<p><b>Excessive temperatures due to dry running or excessive gas content in the fluid handled</b>  Explosion hazard!  Damage to the pump set!</p> <ul style="list-style-type: none"> <li>▷ Never operate the pump set without liquid fill.</li> <li>▷ Prime the pump as per operating instructions. (⇒ Section 6.1.4, Page 33)</li> <li>▷ Always operate the pump within the permissible operating range.</li> </ul>

	<p><b>CAUTION</b></p>
	<p><b>Abnormal noises, vibrations, temperatures or leakage</b>  Damage to the pump!</p> <ul style="list-style-type: none"> <li>▷ Switch off the pump (set) immediately.</li> <li>▷ Eliminate the causes before returning the pump set to service.</li> </ul>

- ✓ The system piping has been cleaned.
- ✓ Pump, suction line and inlet tank, if any, have been vented and primed with the fluid to be pumped.
- ✓ The lines for priming and venting have been closed.

	<p><b>CAUTION</b></p>
	<p><b>Start-up against open discharge line</b>  Motor overload!</p> <ul style="list-style-type: none"> <li>▷ Make sure the motor has sufficient power reserves.</li> <li>▷ Use a soft starter.</li> <li>▷ Use speed control.</li> </ul>

1. Fully open the shut-off element in the suction head/suction lift line.
2. Close or slightly open the shut-off element in the discharge line.
3. Start up the motor.
4. Immediately after the pump has reached rated speed, slowly open the shut-off element in the discharge line and adjust it to comply with the duty point.

	<p><b>CAUTION</b></p>
	<p><b>Misalignment of pump and coupling</b>  Damage to pump, motor and coupling!</p> <ul style="list-style-type: none"> <li>▷ When the operating temperature has been reached, switch off the pump set and check the coupling alignment.</li> </ul>

5. Check the coupling alignment and re-align the coupling, if required.

**6.1.12 Checking the shaft seal**

**Mechanical seal** The mechanical seal only leaks slightly or invisibly (as vapour) during operation. Mechanical seals are maintenance-free.

**6.1.13 Shutdown**

- ✓ The shut-off element in the suction line is and remains open.
- ✓ On pump sets with double mechanical seal, apply the required pressure specified in the general arrangement drawing to the mechanical seal chamber also during standstill.
- ✓ Also ensure quench liquid supply is ON during pump standstill.
  1. Close the shut-off element in the discharge line.
  2. Switch off the motor and make sure the pump set runs down smoothly to a standstill.

	<b>NOTE</b>
	If the discharge line is equipped with a non-return or check valve, the shut-off element may remain open provided that the system conditions and system regulations are considered and observed.

	<b>NOTE</b>
	If shut-off is not possible, the pump will run in reverse direction. The reverse runaway speed must be lower than the rated speed.

For prolonged shutdown periods:

1. Close the shut-off element in the suction line.
2. Close the auxiliary connections.  
If the fluid to be handled is fed in under vacuum, also supply the shaft seal with barrier fluid during standstill.  
Only turn off the cooling liquid supply after the pump has cooled down.

	<b>CAUTION</b>
	<p><b>Risk of freezing during prolonged pump shutdown periods</b></p> <p>Damage to the pump!</p> <ul style="list-style-type: none"> <li>▷ Drain the pump and the cooling/heating chambers (if any) or otherwise protect them against freezing.</li> </ul>

**6.2 Operating limits**

 	<b>⚠ DANGER</b>
	<p><b>Non-compliance with operating limits for pressure, temperature, fluid handled and speed</b></p> <p>Explosion hazard! Hot or toxic fluid could escape!</p> <ul style="list-style-type: none"> <li>▷ Comply with the operating data indicated in the data sheet.</li> <li>▷ Never use the pump for handling fluids it is not designed for.</li> <li>▷ Avoid prolonged operation against a closed shut-off element.</li> <li>▷ Never operate the pump at temperatures, pressures or rotational speeds exceeding those specified in the data sheet or on the name plate unless the written consent of the manufacturer has been obtained.</li> </ul>

	<b>⚠ DANGER</b>
	<p><b>Formation of a potentially explosive atmosphere inside the pump</b></p> <p>Explosion hazard!</p> <ul style="list-style-type: none"> <li>▷ When draining tanks take suitable measures to prevent dry running of the pump (e.g. fill level monitoring).</li> </ul>

6.2.1 Ambient temperature

	<b>CAUTION</b>
	<p><b>Operation outside the permissible ambient temperature</b>                  Damage to the pump (set)!</p> <ul style="list-style-type: none"> <li>▸ Observe the specified limits for permissible ambient temperatures.</li> </ul>

Observe the following parameters and values during operation:

**Table 14:** Permissible ambient temperatures

Permissible ambient temperature	Value
Maximum	50 °C 40 °C <sup>10)</sup>
Minimum	See data sheet

6.2.2 Frequency of starts

	<b>! DANGER</b>
	<p><b>Excessive surface temperature of the motor</b>                  Explosion hazard!                  Damage to the motor!</p> <ul style="list-style-type: none"> <li>▸ In case of explosion-proof motors, observe the frequency of starts specified in the manufacturer's product literature.</li> </ul>

The frequency of starts is usually determined by the maximum temperature increase of the motor. This largely depends on the power reserves of the motor in steady-state operation and on the starting conditions (DOL, star-delta, moments of inertia, etc). If the starts are evenly spaced over the period indicated, the following limits serve as orientation for start-up with the discharge-side gate valve slightly open:

**Table 15:** Frequency of starts

Motor rating [kW]	Maximum frequency of starts [Starts/hour]
≤ 12	15
≤ 100	10
> 100	5

	<b>CAUTION</b>
	<p><b>Re-starting while motor is still running down</b>                  Damage to the pump (set)!</p> <ul style="list-style-type: none"> <li>▸ Do not re-start the pump set before the pump rotor has come to a standstill.</li> </ul>

6.2.3 Fluid handled

6.2.3.1 Flow rate

Unless specified otherwise in the characteristic curves or in the data sheets, the following applies:

$Q_{max}$ <sup>11)</sup> See characteristic curves.

10) For compliance with 2014/34/EU (ATEX Equipment Directive). Higher ambient temperature possible in individual cases, see data sheet and name plate.  
 11) Maximum permissible flow rate

$$Q_{\min}^{12)} = 0.3 \times Q_{\text{opt}}^{13)}$$

The data refer to water and water-like fluids. Longer operating periods with these fluids and at the flow rates indicated will not cause an additional increase in the temperatures on the pump surface. However, if the physical properties of the fluids handled differ from those of water, the calculation formula below must be used to check if an additional heat build-up may lead to a dangerous temperature increase at the pump surface. If necessary, the minimum flow must be increased.

$$T_o = T_f + \Delta \vartheta$$

$$\Delta \vartheta = \frac{g \times H}{c \times \eta} \times (1 - \eta)$$

**Table 16: Key**

Symbol	Description	Unit
c	Specific heat capacity	J/kg K
g	Gravitational constant	m/s <sup>2</sup>
H	Pump discharge head	m
T <sub>f</sub>	Fluid temperature	°C
T <sub>o</sub>	Temperature at the casing surface	°C
η	Pump efficiency at duty point	-
Δϑ	Temperature difference	K

### 6.2.3.2 Density of the fluid handled

The pump input power changes in proportion to the density of the fluid handled.

	<b>CAUTION</b>
	<p><b>Impermissibly high density of the fluid handled</b>  <b>Motor overload!</b></p> <ul style="list-style-type: none"> <li>▷ Observe the information about fluid density in the data sheet.</li> <li>▷ Make sure the motor has sufficient power reserves.</li> </ul>

### 6.2.3.3 Abrasive fluids

Do not exceed the maximum permissible solids content specified in the data sheet. When the pump handles fluids containing abrasive substances, increased wear of the hydraulic system and shaft seal are to be expected. In this case, reduce the commonly recommended inspection intervals.

## 6.3 Shutdown/storage/preservation

### 6.3.1 Measures to be taken for shutdown

#### The pump (set) remains installed

- ✓ Sufficient fluid is supplied for the operation check run of the pump.
  1. For prolonged shutdown periods, start up the pump (set) regularly between once a month and once every three months for approximately five minutes.
    - ⇒ This will prevent the formation of deposits within the pump and the pump intake area.

12) Minimum permissible flow rate  
 13) Best efficiency point



**The pump (set) is removed from the pipe and stored**



- ✓ The pump has been properly drained. (⇒ Section 7.3, Page 49)
- ✓ The safety instructions for dismantling the pump have been observed. (⇒ Section 7.4.1, Page 49)
  1. Spray-coat the inside wall of the pump casing and, in particular, the impeller clearance areas with a preservative.
  2. Spray the preservative through the suction nozzle and discharge nozzle. It is advisable to then close the pump nozzles (e.g. with plastic caps).
  3. Oil or grease all exposed machined parts and surfaces of the pump (with silicone-free oil or grease, food-approved if required) to protect them against corrosion.  
Observe the additional instructions on preservation. (⇒ Section 3.3, Page 14)

If the pump set is to be stored temporarily, only preserve the wetted components made of low-alloy materials. Commercially available preservatives can be used for this purpose. Observe the manufacturer's instructions for application/removal.

**6.4 Returning to service**

For returning the equipment to service observe the sections on commissioning/start-up and the operating limits. (⇒ Section 6.1, Page 31) (⇒ Section 6.2, Page 38)

In addition, carry out all servicing/maintenance operations before returning the pump (set) to service. (⇒ Section 7, Page 42)

	<p style="background-color: #f4a460; padding: 5px;"><b>⚠ WARNING</b></p> <p><b>Failure to re-install or re-activate protective devices</b> Risk of injury from moving parts or escaping fluid!</p> <ul style="list-style-type: none"> <li>▸ As soon as the work is completed, re-install and re-activate any safety-relevant devices and protective devices.</li> </ul>
	<p style="background-color: #0070c0; color: white; padding: 5px;"><b>NOTE</b></p> <p>If the pump has been out of service for more than one year, replace all elastomer seals.</p>

## 7 Servicing/Maintenance

### 7.1 Safety regulations

	<p><b>⚠ DANGER</b></p> <p><b>Improper cleaning of coated pump surfaces</b> Explosion hazard by electrostatic discharge!</p> <ul style="list-style-type: none"> <li>▷ When cleaning coated pump surfaces in atmospheres of Explosion group IIC, use suitable anti-static equipment.</li> </ul>
	<p><b>⚠ DANGER</b></p> <p><b>Sparks produced during servicing work</b> Explosion hazard!</p> <ul style="list-style-type: none"> <li>▷ Observe the safety regulations in force at the place of installation!</li> <li>▷ Always perform maintenance work at an explosion-proof pump (set) outside of potentially explosive atmospheres.</li> </ul>
	<p><b>⚠ DANGER</b></p> <p><b>Improperly serviced pump set</b> Explosion hazard! Damage to the pump set!</p> <ul style="list-style-type: none"> <li>▷ Service the pump set regularly.</li> <li>▷ Prepare a maintenance schedule with special emphasis on lubricants, shaft seal and coupling.</li> </ul>
<p>The operator ensures that maintenance, inspection and installation is performed by authorised, qualified specialist personnel who are thoroughly familiar with the manual.</p>	
	<p><b>⚠ WARNING</b></p> <p><b>Unintentional starting of the pump set</b> Risk of injury by moving components and shock currents!</p> <ul style="list-style-type: none"> <li>▷ Ensure that the pump set cannot be started unintentionally.</li> <li>▷ Always make sure the electrical connections are disconnected before carrying out work on the pump set.</li> </ul>
	<p><b>⚠ WARNING</b></p> <p><b>Fluids handled, consumables and supplies which are hot and/or pose a health hazard</b> Risk of injury!</p> <ul style="list-style-type: none"> <li>▷ Observe all relevant laws.</li> <li>▷ When draining the fluid take appropriate measures to protect persons and the environment.</li> <li>▷ Decontaminate pumps which handle fluids posing a health hazard.</li> </ul>

	<p><b>⚠ WARNING</b></p>
	<p><b>Insufficient stability</b>          Risk of crushing hands and feet!</p> <ul style="list-style-type: none"> <li>▷ During assembly/dismantling, secure the pump (set)/pump parts to prevent tilting or tipping over.</li> </ul>

A regular maintenance schedule will help avoid expensive repairs and contribute to trouble-free, reliable operation of the pump, pump set and pump parts with a minimum of servicing/maintenance expenditure and work.

	<p><b>NOTE</b></p>
	<p>All maintenance work, service work and installation work can be carried out by KSB Service or authorised workshops. For contact details please refer to the enclosed "Addresses" booklet or visit "<a href="http://www.ksb.com/contact">www.ksb.com/contact</a>" on the Internet.</p>

Never use force when dismantling and reassembling the pump set.



## 7.2 Servicing/Inspection

### 7.2.1 Supervision of operation

	<p><b>⚠ DANGER</b></p>
	<p><b>Risk of potentially explosive atmosphere inside the pump</b>          Explosion hazard!</p> <ul style="list-style-type: none"> <li>▷ The pump internals in contact with the fluid to be handled, including the seal chamber and auxiliary systems must be filled with the fluid to be handled at all times.</li> <li>▷ Provide sufficient inlet pressure.</li> <li>▷ Provide an appropriate monitoring system.</li> </ul>

 	<p><b>⚠ DANGER</b></p>
	<p><b>Excessive temperatures as a result of bearings running hot or defective bearing seals</b>          Explosion hazard!          Fire hazard!          Damage to the pump set!          Risk of burns!</p> <ul style="list-style-type: none"> <li>▷ Regularly check the lubricant level.</li> <li>▷ Regularly check the rolling element bearings for running noises.</li> </ul>

 	<p><b>⚠ DANGER</b></p>
	<p><b>Incorrectly serviced shaft seal</b>          Explosion hazard!          Hot, toxic fluid escaping!          Damage to the pump set!          Risk of burns!          Fire hazard!</p> <ul style="list-style-type: none"> <li>▷ Regularly service the shaft seal.</li> </ul>

	<p><b>⚠ DANGER</b></p> <p><b>Incorrectly serviced barrier fluid system</b>                  Explosion hazard!                  Fire hazard!                  Damage to the pump set!                  Hot and/or toxic fluids escaping!</p> <ul style="list-style-type: none"> <li>▷ Regularly service the barrier fluid system.</li> <li>▷ Monitor the barrier fluid pressure.</li> </ul>
	<p><b>CAUTION</b></p> <p><b>Increased wear due to dry running</b>                  Damage to the pump set!</p> <ul style="list-style-type: none"> <li>▷ Never operate the pump set without liquid fill.</li> <li>▷ Never close the shut-off element in the suction line and/or supply line during pump operation.</li> </ul>
	<p><b>CAUTION</b></p> <p><b>Impermissibly high temperature of fluid handled</b>                  Damage to the pump!</p> <ul style="list-style-type: none"> <li>▷ Prolonged operation against a closed shut-off element is not permitted (heating up of the fluid).</li> <li>▷ Observe the temperature limits in the data sheet and in the section on operating limits. (⇒ Section 6.2, Page 38)</li> </ul>

While the pump is in operation, observe and check the following:

- The pump must run quietly and free from vibrations at all times.
- In case of oil lubrication, ensure the oil level is correct.
- Check the shaft seal.
- Check the static sealing elements for leakage.
- Check the rolling element bearings for running noises.  
 Vibrations, noise and an increase in current input occurring during unchanged operating conditions indicate wear.
- Monitor the correct functioning of any auxiliary connections.
- Cooling system  
 Take the pump out of service at least once a year to thoroughly clean the cooling system.
- Monitor the stand-by pump.  
 To make sure that stand-by pumps are ready for operation, start them up once a week.
- Keep the stand-by pump warm.  
 Observe the following conditions to make sure stand-by pumps are operational and kept warm:
  - All cooling points are in operation.
  - The permissible nozzle forces and moments are not exceeded.
  - In extreme cases, contact the manufacturer.
- Monitor the bearing temperature.  
 The bearing temperature must not exceed 90 °C (measured on the outside of the bearing bracket).

	<b>CAUTION</b>
	<p><b>Operation outside the permissible bearing temperature</b>                  Damage to the pump!</p> <ul style="list-style-type: none"> <li>▷ The bearing temperature of the pump (set) must never exceed 90 °C (measured on the outside of the bearing bracket).</li> </ul>

**7.2.2 Inspection work**

	<b>⚠ DANGER</b>
	<p><b>Excessive temperatures caused by friction, impact or frictional sparks</b>                  Explosion hazard!                  Fire hazard!                  Damage to the pump set!</p> <ul style="list-style-type: none"> <li>▷ Regularly check the coupling guard, plastic components and other guards of rotating parts for deformation and sufficient distance from rotating parts.</li> </ul>

	<b>⚠ DANGER</b>
	<p><b>Static charging due to insufficient potential equalisation</b>                  Explosion hazard!</p> <ul style="list-style-type: none"> <li>▷ Make sure that the connection between pump and baseplate is electrically conductive.</li> </ul>

**7.2.2.1 Checking the coupling**

Check the flexible elements of the coupling. Replace the relevant parts in due time if there is any sign of wear and check the alignment.

**7.2.2.2 Checking the clearances**

For checking the clearances gaps remove impeller 230, if required.

(⇒ Section 7.4.5, Page 51)

If the clearance is larger than permitted (see the following table), replace casing wear ring 502.01/502.02 and/or impeller wear ring 503.01/503.02.

The clearances given refer to the diameter.

**Table 17:** Clearances between impeller and casing and between impeller and casing cover

Size	Suction-side casing wear ring				Discharge-side casing wear ring			
	Inside diameter	Diametral clearance			Inside diameter	Diametral clearance		
		As-supplied	Worn	Worn		As-supplied	Worn	Worn
	[mm]							
Nominal	Min.	Max.	Max.	Nominal	Min.	Max.	Max.	
25-180	70	0,50	0,60	1,00	70	0,50	0,60	1,00
25-230	70	0,50	0,60	1,00	70	0,50	0,60	1,00
40-180	80	0,50	0,60	1,00	80	0,50	0,60	1,00
40-230	80	0,50	0,60	1,00	80	0,50	0,60	1,00
40-280	85	0,60	0,70	1,20	120	0,60	0,70	1,20
40-181	95	0,60	0,70	1,20	95	0,60	0,70	1,20
40-231	95	0,60	0,70	1,20	95	0,60	0,70	1,20
40-281	95	0,60	0,70	1,20	120	0,60	0,70	1,20
40-361	95	0,60	0,70	1,20	165	0,60	0,71	1,20
50-180	120	0,60	0,70	1,20	120	0,60	0,70	1,20
50-230	120	0,60	0,70	1,20	120	0,60	0,70	1,20

Size	Suction-side casing wear ring				Discharge-side casing wear ring			
	Inside diameter	Diametral clearance			Inside diameter	Diametral clearance		
		As-supplied	Worn	Worn		As-supplied	Worn	Worn
	[mm]							
Nominal	Min.	Max.	Max.	Nominal	Min.	Max.	Max.	
50-280	120	0,60	0,70	1,20	120	0,60	0,70	1,20
50-360	120	0,60	0,70	1,20	165	0,60	0,71	1,20
50-450	120	0,60	0,70	1,20	195	0,60	0,75	1,20
80-180	135	0,60	0,71	1,20	135	0,60	0,71	1,20
80-230	135	0,60	0,71	1,20	135	0,60	0,71	1,20
80-280	135	0,60	0,71	1,20	135	0,60	0,71	1,20
80-360	135	0,60	0,71	1,20	165	0,60	0,71	1,20
80-450	135	0,60	0,71	1,20	195	0,60	0,75	1,20
100-180	165	0,40	0,51	0,80	165	0,40	0,51	0,80
100-230	165	0,60	0,71	1,20	165	0,60	0,71	1,20
100-280	165	0,60	0,71	1,20	165	0,60	0,71	1,20
100-360	165	0,60	0,71	1,20	165	0,60	0,71	1,20
100-450	175	0,60	0,71	1,20	195	0,70	0,85	1,40
150-230	195	0,70	0,85	1,40	195	0,70	0,85	1,40
150-280	195	0,70	0,85	1,40	195	0,70	0,85	1,40
150-360	195	0,70	0,85	1,40	195	0,70	0,85	1,40
150-450	200	0,70	0,85	1,40	235	0,70	0,85	1,40
150-501	225	0,60	0,75	1,20	225	0,60	0,75	1,20
150-630	240	0,70	0,85	1,40	290	0,70	0,86	1,40
200-280	225	0,70	0,85	1,40	225	0,70	0,85	1,40
200-360	235	0,70	0,85	1,40	280	0,70	0,86	1,40
200-450	235	0,70	0,85	1,40	280	0,70	0,86	1,40
200-401	250	0,60	0,72	1,20	250	0,60	0,72	1,20
200-501	255	0,60	0,76	1,20	255	0,60	0,76	1,20
200-670	290	0,60	0,73	1,20	290	0,60	0,73	1,20
250-401	330	0,75	0,92	1,50	330	0,75	0,92	1,50
250-501	310	0,60	0,76	1,20	310	0,60	0,76	1,20
250-630	330	0,75	0,94	1,50	340	0,75	0,94	1,50
250-710	310	0,70	0,86	1,40	340	0,80	0,99	1,60
300-400	330	0,75	0,92	1,50	330	0,75	0,92	1,50
300-500	350	0,75	0,94	1,50	350	0,75	0,94	1,50
300-630	360	0,85	1,04	1,70	340	0,75	0,94	1,50
350-400A	380	0,85	1,04	1,70	340	0,85	1,04	1,70
350-400B	350	0,85	1,04	1,70	340	0,85	1,04	1,70
350-500	380	0,85	1,04	1,70	380	0,85	1,04	1,70
350-630	400	0,85	1,04	1,70	400	0,85	1,04	1,70
350-710	440	0,85	1,05	1,70	440	0,85	1,05	1,70
400-504	410	0,85	1,05	1,70	410	0,85	1,05	1,70
400-506	440	0,85	1,05	1,70	440	0,85	1,05	1,70
400-710	440	0,85	1,05	1,70	500	0,85	1,05	1,70

7.2.2.3 Cleaning filters

	<b>CAUTION</b>
	<p><b>Insufficient inlet pressure due to clogged filter in the suction line</b>                  Damage to the pump!</p> <ul style="list-style-type: none"> <li>▷ Monitor contamination of filter with suitable means (e.g. differential pressure gauge).</li> <li>▷ Clean filter at appropriate intervals.</li> </ul>

7.2.3 Lubrication and lubricant change of rolling element bearings

	<b>⚠ DANGER</b>
	<p><b>Excessive temperatures as a result of bearings running hot or defective bearing seals</b>                  Explosion hazard!                  Fire hazard!                  Damage to the pump set!</p> <ul style="list-style-type: none"> <li>▷ Regularly check the condition of the lubricant.</li> </ul>

7.2.3.1 Oil lubrication

The rolling element bearings are usually lubricated with mineral oil.

7.2.3.1.1 Intervals

Table 18: Oil change intervals

Temperature at the bearing	First oil change	All subsequent oil changes <sup>14)</sup>
up to 70 °C	After 300 operating hours	Every 8500 operating hours
70 °C - 80 °C	After 300 operating hours	Every 4200 operating hours
80 °C - 90 °C	After 300 operating hours	Every 2000 operating hours

7.2.3.1.2 Oil quality

Oil quality Table 19: Oil quality

Designation	Symbol to DIN 51502	Characteristics	
		CLP46 lubricating oil to DIN 51517 or HD 20W/20 SAE	□
Flash point (to Cleveland)	+175 °C		
Solidification point (pour point)	-15 °C		
Application temperature <sup>15)</sup>	Higher than permissible bearing temperature		

14) At least once a year

15) For ambient temperatures below -10 °C use a different suitable type of lubricating oil. Contact KSB.

7.2.3.1.3 Oil quantity

Bearing bracket	Oil quantity bearing bracket [l]
B02	0.9
B03	1.8
B05	2.5
B06	5.7
B07	4.7

7.2.3.1.4 Changing the oil

	<b>WARNING</b>
	<p><b>Lubricants posing a health hazard and/or hot lubricants</b> Hazard to persons and the environment!</p> <ul style="list-style-type: none"> <li>▷ When draining the lubricant take appropriate measures to protect persons and the environment.</li> <li>▷ Wear safety clothing and a protective mask if required.</li> <li>▷ Collect and dispose of any lubricants.</li> <li>▷ Observe all legal regulations on the disposal of fluids posing a health hazard.</li> </ul>

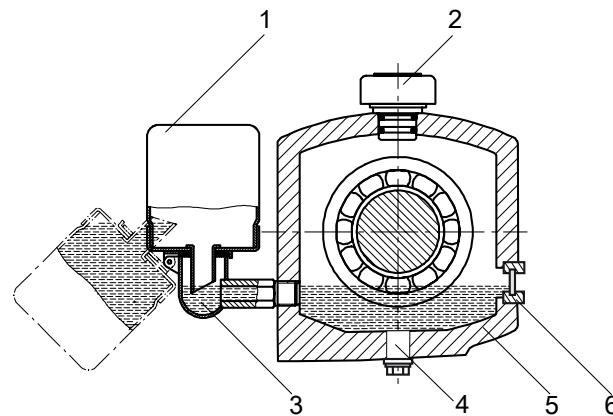



Fig. 13: Bearing bracket with constant level oiler

1	Constant-level oiler	2	Vent plug
3	Connection elbow of the constant level oiler	4	Screw plug
5	Bearing bracket	6	Oil level sight glass

- ✓ A suitable container for the used oil is on hand.
- 1. Place the container underneath the screw plug.
- 2. Undo screw plug (4) at bearing bracket (5) and drain the oil.
- 3. Once bearing bracket (5) has been drained, re-insert and re-tighten screw plug (4).
- 4. Re-fill with oil.



### 7.3 Drainage/cleaning



	 <b>WARNING</b>
	<p><b>Fluids handled, consumables and supplies which are hot and/or pose a health hazard</b></p> <p>Hazard to persons and the environment!</p> <ul style="list-style-type: none"> <li>▸ Collect and properly dispose of flushing fluid and any fluid residues.</li> <li>▸ Wear safety clothing and a protective mask if required.</li> <li>▸ Observe all legal regulations on the disposal of fluids posing a health hazard.</li> </ul>



If the pump set has handled fluids whose residues could lead to corrosion damage in the presence of atmospheric humidity or could ignite upon contact with oxygen, the pump set must be neutralised, and anhydrous inert gas must be blown through the pump to ensure drying.



Use connection 6B to drain the fluid handled (see drawing of auxiliary connections).

### 7.4 Dismantling the pump set

#### 7.4.1 General information/Safety regulations

	 <b>WARNING</b>
	<p><b>Unqualified personnel performing work on the pump (set)</b></p> <p>Risk of injury!</p> <ul style="list-style-type: none"> <li>▸ Always have repair work and maintenance work performed by specially trained, qualified personnel.</li> </ul>

	 <b>WARNING</b>
	<p><b>Hot surface</b></p> <p>Risk of injury!</p> <ul style="list-style-type: none"> <li>▸ Allow the pump set to cool down to ambient temperature.</li> </ul>



	 <b>WARNING</b>
	<p><b>Improper lifting/moving of heavy assemblies or components</b></p> <p>Personal injury and damage to property!</p> <ul style="list-style-type: none"> <li>▸ Use suitable transport devices, lifting equipment and lifting tackle to move heavy assemblies or components.</li> </ul>

Observe the general safety instructions and information. (⇒ Section 7, Page 42)

For any work on the motor, observe the instructions of the relevant motor manufacturer.

For dismantling and reassembly refer to the general assembly drawing. (⇒ Section 9.1, Page 66)

In the event of damage you can always contact our service departments.



	 <b>DANGER</b>
	<p><b>Insufficient preparation of work on the pump (set)</b> Risk of injury!</p> <ul style="list-style-type: none"> <li>▷ Properly shut down the pump set. (⇒ Section 6.1.13, Page 38)</li> <li>▷ Close the shut-off elements in the suction line and discharge line.</li> <li>▷ Drain the pump and release the pump pressure. (⇒ Section 7.3, Page 49)</li> <li>▷ Shut off any auxiliary feed lines.</li> <li>▷ Allow the pump set to cool down to ambient temperature.</li> </ul>

**7.4.2 Preparing the pump set**

1. Interrupt the power supply and secure the pump against unintentional start-up.
2. Disconnect and remove all auxiliary pipework.
3. Remove the coupling guard.
4. Remove the coupling spacer, if any.
5. Drain the oil fill of oil-lubricated bearings.

**7.4.3 Removing the motor**



	<b>NOTE</b>
	<p>On pump sets with spacer-type couplings, the back pull-out unit can be removed while the motor remains bolted to the baseplate.</p>

	 <b>WARNING</b>
	<p><b>Motor tilting</b> Risk of crushing hands and feet!</p> <ul style="list-style-type: none"> <li>▷ Suspend or support the motor to prevent it from tilting.</li> </ul>

1. Disconnect the motor from the power supply.
2. Unbolt the motor from the baseplate.
3. Shift the motor to separate it from the pump.

**7.4.4 Removing the back pull-out unit**

✓ At pump sets without spacer-type coupling, the motor has been removed.

	 <b>WARNING</b>
	<p><b>Back pull-out unit tilting</b> Risk of crushing hands and feet!</p> <ul style="list-style-type: none"> <li>▷ Suspend or support the bearing bracket at the pump end.</li> </ul>

1. If required, suspend or support bearing bracket 330 to prevent it from tipping over.
2. Remove hexagon nut 920.01 at volute casing 102.
3. Use forcing screws 901.30 to pull the back pull-out unit out of volute casing 102.
4. Remove and dispose of joint ring 411.10.
5. Place the back pull-out unit on a clean and level surface.

### 7.4.5 Removing the impeller

#### 7.4.5.1 Loosening the impeller — for bearing brackets B02 to B05

- ✓ The notes and steps stated in (⇒ Section 7.4.1, Page 49) to (⇒ Section 7.4.4, Page 50) have been observed/carried out.
- ✓ The back pull-out unit has been placed in a clean and level assembly area.
  1. Unscrew impeller nut 922.01 with threaded insert (right-hand thread).  
**For versions with auxiliary impeller:** Unscrew auxiliary impeller 23-2 with the threaded insert (right-hand thread).
  2. Remove and dispose of joint ring 411.31, if any
  3. Remove lock washer 931.02.

#### 7.4.5.2 Loosening the impeller — for bearing brackets B06 and B07

- ✓ The notes and steps stated in (⇒ Section 7.4.1, Page 49) to (⇒ Section 7.4.4, Page 50) have been observed/carried out.
- ✓ The back pull-out unit has been placed in a clean and level assembly area.
  1. Unscrew and remove impeller hub cap 260 (right-hand thread).  
**For versions with auxiliary impeller:** Unscrew and remove impeller hub cap 260.01 (right-hand thread).
  2. Remove and dispose of joint ring 411.31.  
**For versions with auxiliary impeller:** Remove and dispose of joint ring 411.59.
  3. Bend open lock washer 931.02.
  4. Remove impeller screw 906 with lock washer 931.02 and disc 550.87.  
**For versions with auxiliary impeller:** Pull auxiliary impeller 23-2 off the shaft. Remove keys 940.03 from shaft 210. Remove and dispose of joint ring 411.31.

#### 7.4.5.3 Removing the impeller — for all bearing bracket sizes

- ✓ The notes and steps (⇒ Section 7.4.1, Page 49) stated in to (⇒ Section 7.4.5.2, Page 51) have been observed/carried out.
  1. Remove impeller 230 with an impeller removal tool.
  2. Place impeller 230 on a clean and level surface.
  3. Remove keys 940.01 from shaft 210.
  4. If throttling bush 542.02 is fitted, undo grub screws 904.38.
  5. Remove throttling bush 542.02, if any.

### 7.4.6 Removing the cartridge seal

- ✓ The notes and steps stated in (⇒ Section 7.4.1, Page 49) to (⇒ Section 7.4.5.3, Page 51) have been observed/carried out.
- ✓ The back pull-out unit is kept in a clean and level assembly area.
  1. If assembling jigs are provided, loosen the hexagon head bolts for fitting the assembling jigs.
  2. Engage assembling jigs, if any, in the groove of shaft protecting sleeve 524.01 and re-tighten the hexagon head bolts.
  3. Loosen hexagon head bolts 920.15 at casing cover 161.
  4. Use forcing screws 901.31 to remove bearing bracket 330.  
 At the same time, pull shaft protecting sleeve 524.01 (if any) with complete cartridge seal 433 off shaft 210.
  5. Take care not to damage O-rings 412.01/31, if any.
  6. Undo hexagon nut 920.02 and remove seal cover 471.01 and/or the seal cartridge.  
 Observe the seal installation drawing of the mechanical seal.

**7.4.7 Dismantling the bearings**

- ✓ The notes and steps stated in (⇒ Section 7.4.1, Page 49) to (⇒ Section 7.4.6, Page 51) have been observed/carried out.
- ✓ The bearing bracket has been placed in a clean and level assembly area.
  1. Undo the hexagon socket head cap screw in the coupling hub.
  2. Pull the coupling half off the pump shaft with a puller.
  3. Remove key 940.02.
  4. Remove fan hood 882, fan hub 485.02 and fan wheel 831.02, if any.
  5. Undo hexagon nut 920.02 and remove seal cover 471.01 and/or the seal cartridge.
  6. Undo grub screws 904.41/42 and remove throwers 507.01/02.
  7. Undo hexagon socket head cap screws 914.01 and remove pump-end bearing cover 360.01 as well as joint ring 400.01.
  8. Undo hexagon head bolts 901.37 and remove motor-end bearing cover 360.02 as well as O-ring 412.22, if required.
  9. Carefully drive shaft 210 together with angular contact ball bearing 320.02 and the inner ring of cylindrical roller bearing 322.01, including oil thrower 508.01, if any, out of the bearing bracket towards the drive end.
  10. Remove cylindrical roller bearing 322.01 (roller cage) from bearing bracket 330.
  11. If oil thrower 508.01 is fitted, remove grub screw 904.20 and pull the oil thrower off the shaft.
  12. Bend open lock washer 931.01 behind slotted round nut 920.21 on shaft 210.
  13. Unscrew slotted round nut 920.21 (right-hand thread) and remove lock washer 931.01.

	<p><b>⚠ WARNING</b></p>
	<p><b>Hot surfaces due to heating of components for assembly/dismantling</b>          Risk of burns!</p> <ul style="list-style-type: none"> <li>▷ Wear heat-resistant protective gloves.</li> <li>▷ Remove flammable substances from the danger zone.</li> </ul>

- 14. Heat up angular contact ball bearing 320.02 and the inner ring of cylindrical roller bearing 322.01 to 80 °C, and pull them off shaft 210.

**7.5 Reassembling the pump set**

**7.5.1 General information/Safety regulations**

	<p><b>⚠ WARNING</b></p>
	<p><b>Improper lifting/moving of heavy assemblies or components</b>          Personal injury and damage to property!</p> <ul style="list-style-type: none"> <li>▷ Use suitable transport devices, lifting equipment and lifting tackle to move heavy assemblies or components.</li> </ul>

	<p><b>CAUTION</b></p>
	<p><b>Improper reassembly</b>          Damage to the pump!</p> <ul style="list-style-type: none"> <li>▷ Reassemble the pump (set) in accordance with the general rules of sound engineering practice.</li> <li>▷ Use original spare parts only.</li> </ul>

**Sequence** Always reassemble the pump in accordance with the corresponding general assembly drawing.

- Sealing elements**
- **Gaskets**
    - Always use new gaskets, making sure that they have the same thickness as the old ones.
    - Always fit gaskets of asbestos-free materials or graphite without using lubricants (e.g. copper grease, graphite paste).
  - **O-rings**
    - Never use O-rings that have been made by cutting an O-ring cord to size and gluing the ends together.

	<b>CAUTION</b>
	<p><b>Contact of O-ring with graphite or similar material</b>          Fluid could escape!</p> <ul style="list-style-type: none"> <li>▷ Do not coat O-ring with graphite or similar material.</li> <li>▷ Use animal fats or lubricants based on silicone or PTFE.</li> </ul>

- **Assembly adhesives**
  - For gaskets, avoid the use of assembly adhesives if possible.
  - If assembly adhesives are required, use a commercially available contact adhesive.
  - Only apply adhesive at selected points and in thin layers.
  - Never use quick-setting adhesives (cyanoacrylate adhesives).
  - Coat the locating surfaces of the individual components and screwed connections with graphite or similar before reassembly.
  - Prior to reassembly, screw back any forcing screws and adjusting screws.

**Tightening torques** For reassembly, tighten all screws and bolts as specified in this manual.

**7.5.2 Fitting the bearings**

- ✓ The individual parts have been placed in a clean and level assembly area.
- ✓ All dismantled parts have been cleaned and checked for wear.
- ✓ Any damaged or worn parts have been replaced by original spare parts.
- ✓ The sealing surfaces have been cleaned.

	<b>WARNING</b>
	<p><b>Hot surfaces due to heating of components for assembly/dismantling</b>          Risk of burns!</p> <ul style="list-style-type: none"> <li>▷ Wear heat-resistant protective gloves.</li> <li>▷ Remove flammable substances from the danger zone.</li> </ul>

1. Heat up angular contact ball bearing 320.02 and the inner ring of cylindrical roller bearing 322.01 in an oil bath or by means of an induction heater to approximately 80 °C.
2. Slide angular contact ball bearing 320.02 onto shaft 210 as far as it will go.
3. Slide the inner ring of cylindrical roller bearing 322.01 onto shaft 210 as far as it will go.
4. For bearing brackets B03 and B05 make sure that disc 550 is positioned correctly.

**NOTE**

Angular contact ball bearings must be installed in back-to-back arrangement. Angular contact ball bearings installed in pairs must always be from the same manufacturer.

5. Use a C-spanner to tighten slotted round nut 920.21 (right-hand thread) without lock washer 931.01.
6. Let angular contact ball bearing 320.01 cool down to approximately 5 °C above ambient temperature.
7. Re-tighten slotted round nut 920.21, then unscrew it again.
8. Apply a few spots of a suitable lubricant (e.g. Molykote) to the contact faces of lock washer 931.01 and slotted round nut 920.21.
9. Fit lock washer 931.01.
10. Tighten slotted round nut 920.21.
11. Bend back lock washer 931.01.
12. If provided, slide oil thrower 508.01 onto shaft 210.
13. Screw grub screw 904.20 into oil thrower 508.01.
14. Guide cylindrical roller bearing 322.01 (roller cage) into bearing bracket 330.
15. Carefully insert shaft 210 together with angular contact ball bearing 320.02 and the inner ring of cylindrical roller bearing 322.01, including oil thrower 508.01 (if any) into bearing bracket 330 towards the pump end.
16. Insert O-ring 412.22 into the groove of motor-end bearing cover 360.02.
17. Insert motor-end bearing cover 360.02 with O-ring 412.22 into bearing bracket 330 from the motor end.
18. Screw hexagon head bolts 901.37 with bearing cover 360.02 into bearing bracket 330 from the motor end.
19. Fit pump-end bearing cover 360.01 with joint ring 400.01.
20. Screw hexagon socket head cap screws 914.01 into bearing bracket 330.
21. Slide thrower 507.01 onto shaft 210 from the pump end, leaving a 2-mm gap between the thrower and pump-end bearing cover 360.01.
22. Screw grub screw 904.41 into pump-end thrower 507.01.
23. Slide thrower 507.02 onto shaft 210 from the motor end, leaving a 2-mm gap between the thrower and motor-end bearing cover 360.02.
24. Screw grub screw 904.21 into motor-end thrower 507.02.
25. Fit fan hood 882, fan hub 485.02 and fan impeller 831.02, if any.
26. From the motor end, insert key 940.02 into the keyway at the shaft end.
27. Pull the coupling half onto the shaft end.
28. Screw the hexagon socket head cap screw into the coupling hub.

### 7.5.3 Fitting the shaft seal

#### 7.5.3.1 Installing the cartridge seal

Always observe the following points when installing the cartridge seal:

- Install the cartridge seal as shown in the seal installation drawing.
- Work cleanly and accurately.
- Prevent any damage to the seal faces or O-rings.
- ✓ The notes and steps stated in (⇒ Section 7.5.1, Page 52) to (⇒ Section 7.5.2, Page 53) have been observed and carried out.
  1. Fit seal cover 471 and the cartridge seal and tighten hexagon head bolts 920.02.
  2. Slide casing cover 161 with cartridge seal 433 onto shaft 210 from the pump end.
  3. Carefully slide complete pre-assembled bearing bracket 330 onto studs 902.15, which have been screwed into casing cover 161.
  4. On cooled versions, watch O-rings 412.01/31 at casing cover 161.
  5. Screw casing cover 161 to complete bearing bracket 330 with hexagon nuts 920.15.

### 7.5.4 Fitting the impeller

#### 7.5.4.1 Fitting the impeller — for all bearing bracket sizes

- ✓ The notes and steps stated in (⇒ Section 7.5.1, Page 52) to (⇒ Section 7.5.3.1, Page 55) have been observed and carried out.
- ✓ The back pull-out unit has been placed in a clean and level assembly area.
- ✓ The pre-assembly (motor, shaft, bearing bracket, casing cover) has been placed in a clean and level assembly area.
- ✓ All dismantled parts have been cleaned and checked for wear.
- ✓ Any damaged or worn parts have been replaced by original spare parts.
- ✓ The sealing surfaces have been cleaned.
  1. If applicable, slide throttling bush 542.02 onto impeller 230.
  2. Screw grub screws 904.38 into throttling bush 542.02.
  3. Slide joint ring 411.32, if any, onto shaft 210.
  4. Place key 940.01 into the keyway of shaft 210.
  5. Slide impeller 230 onto shaft 210.

#### 7.5.4.2 Fastening the impeller — for bearing brackets B02 to B05

- ✓ The notes and steps stated in (⇒ Section 7.5.1, Page 52) to (⇒ Section 7.5.4.1, Page 55) have been observed and carried out.
- ✓ The sealing surfaces have been cleaned.
  1. Insert new joint ring 411.31 if applicable.
  2. Insert lock washer 931.02.
  3. Insert new joint ring 411.67 if applicable.
  4. Screw impeller nut 922.01 with threaded insert (right-hand thread) onto shaft 210.

**For versions with auxiliary impeller:** Screw auxiliary impeller 23-2 with threaded insert (right-hand thread) onto shaft 210. Observe the tightening torques. (⇒ Section 7.6.1, Page 57)
  5. Bend over the lock washer.

**7.5.4.3 Fastening the impeller — for bearing brackets B06 and B07**

- ✓ The notes and steps stated in (⇒ Section 7.5.1, Page 52) to (⇒ Section 7.5.4.1, Page 55) have been observed and carried out.
- ✓ The sealing surfaces have been cleaned.
- 1. **Only for versions with auxiliary impeller:** Insert keys 940.03 into shaft 210. Insert a new joint ring 411.31 into impeller 210. Guide auxiliary impeller 23-2 onto the shaft.
- 2. Insert disc 550.87 and lock washer 931.02.
- 3. Screw impeller screw 906 into shaft 210.
- 4. Observe the tightening torques. (⇒ Section 7.6.1, Page 57)
- 5. Bend back lock washer 931.02.
- 6. Insert a new joint ring 411.31 into impeller 230.  
**For versions with auxiliary impeller:** Place a new joint ring 411.59 on auxiliary impeller 23-2. Screw impeller hub cap 260.01 onto auxiliary impeller 23-2.
- 7. Screw impeller hub cap 260 into impeller 230 (right-hand thread).

**7.5.5 Installing the back pull-out unit**

	<p><b>! WARNING</b></p>
	<p><b>Back pull-out unit tilting</b>          Risk of crushing hands and feet!</p> <p>▷ Suspend or support the bearing bracket at the pump end.</p>

- ✓ The notes and steps stated in (⇒ Section 7.5.1, Page 52) to (⇒ Section 7.5.4, Page 55) have been observed and carried out.
- ✓ Any damaged or worn parts have been replaced by original spare parts.
- ✓ The sealing surfaces have been cleaned.
- ✓ For back pull-out units without coupling, fit the coupling in accordance with the manufacturer's instructions.
- 1. If required, suspend or support the back pull-out unit to prevent it from tilting. Then slide it into volute casing 102 with a new gasket 411.10.
- 2. Tighten nut 920.01 at volute casing 102. Observe the tightening torques. (⇒ Section 7.6.1, Page 57)

**7.5.6 Mounting the motor**

	<p><b>NOTE</b></p>
	<p>Steps 1 and 2 do not apply to versions with spacer-type coupling.</p>

1. Shift the motor to connect it to the pump via the coupling.
2. Fasten the motor to the baseplate.
3. Align pump and motor.
4. Connect the motor to the power supply (refer to manufacturer's product literature).



## 7.6 Tightening torques

### 7.6.1 Tightening torques for the pump

Use a torque wrench to tighten the screwed connections (902.01/920.01) between the volute casing and the casing cover.

**Table 20:** Tightening torques for bolted/screwed connections

Material (Asia and Americas)		A 193 Grade B7/ B16 / A 540 Grade B24			A 193 Grade B7/ B16			10.9			--			A276 Type 316 Ti / Type 420		
Material (Europe)		1.7709/1.6772 (Monix 3K)			C35E+QT			8.8			A4-70			1.4571/1.4021		
Bearing bracket	Size	Stud <sup>16)</sup> 902.01			Stud <sup>16)</sup> 902.15			Hexagon head bolt 901.37			Stud <sup>16)</sup> 902.02			Impeller nut 922.01 and impeller screw 906		
		Quantity	Thread	Tightening torques <sup>17/18)</sup>	Quantity	Thread	Tightening torques <sup>17/18)</sup>	Quantity	Thread	Tightening torques <sup>17)</sup>	Quantity	Thread	Tightening torques <sup>17/18)</sup>	Quantity	Thread	Tightening torques <sup>17)</sup>
				[Nm]			[Nm]			[Nm]			[Nm]			[Nm]
B02S	25-180	12	M16	163 <sup>19)</sup> / 280 <sup>20)</sup>	4	M16	83	4	M10	45	4	M16	133	1	M14x1,5	80 <sup>21)</sup>
	25-230	16	M16	163 <sup>19)</sup> / 280 <sup>20)</sup>	4	M16	83	4	M10	45	4	M16	133	1	M14x1,5	80 <sup>21)</sup>
	40-180	12	M16	163 <sup>19)</sup> / 280 <sup>20)</sup>	4	M16	83	4	M10	45	4	M16	133	1	M14x1,5	80 <sup>21)</sup>
	40-230	16	M16	163 <sup>19)</sup> / 280 <sup>20)</sup>	4	M16	83	4	M10	45	4	M16	133	1	M14x1,5	80 <sup>21)</sup>
B02L	40-181	12	M16	163 <sup>19)</sup> / 280 <sup>20)</sup>	4	M16	83	4	M10	45	4	M16	133	1	M16x1,5	130 <sup>21)</sup>
	40-231	16	M16	163 <sup>19)</sup> / 280 <sup>20)</sup>	4	M16	83	4	M10	45	4	M16	133	1	M16x1,5	130 <sup>21)</sup>
	40-280	16	M20	330 <sup>19)</sup> / 565 <sup>20)</sup>	4	M16	83	4	M10	45	4	M16	133	1	M16x1,5	130 <sup>21)</sup>
	40-281	16	M20	330 <sup>19)</sup> / 565 <sup>20)</sup>	4	M16	83	4	M10	45	4	M16	133	1	M16x1,5	130 <sup>21)</sup>
	40-361	20	M20	330 <sup>19)</sup> / 565 <sup>20)</sup>	4	M16	83	4	M10	45	4	M16	133	1	M16x1,5	130 <sup>21)</sup>
	50-180	12	M16	163 <sup>19)</sup> / 280 <sup>20)</sup>	4	M16	83	4	M10	45	4	M16	133	1	M16x1,5	130 <sup>21)</sup>
B03	50-230	12	M20	330 <sup>19)</sup> / 565 <sup>20)</sup>	4	M20	168	4	M12	77	4	M16	133	1	M20x1,5	250 <sup>21)</sup>
	50-280	16	M20	330 <sup>19)</sup> / 565 <sup>20)</sup>	4	M20	168	4	M12	77	4	M16	133	1	M20x1,5	250 <sup>21)</sup>
	50-360	20	M20	330 <sup>19)</sup> / 565 <sup>20)</sup>	4	M20	168	4	M12	77	4	M16	133	1	M20x1,5	250 <sup>21)</sup>
	50-450	20	M24	565 <sup>19)</sup> / 970 <sup>20)</sup>	4	M20	168	4	M12	77	4	M16	133	1	M20x1,5	250 <sup>21)</sup>
	80-180	12	M16	163 <sup>19)</sup> / 280 <sup>20)</sup>	4	M20	168	4	M12	77	4	M16	133	1	M20x1,5	250 <sup>21)</sup>

17) These values are determined on the basis of a friction coefficient  $\mu = 0.12$ .

18) After repeated tightening of the threads and in case of good lubrication the values shall be reduced by 15 to 20 %.

16) Stud to DIN 938/DIN 939 with hexagon nuts to ISO 4032

19) Values for 1.7709 / A 193 Grade B7/B16 /

20) Values for 1.6772 (Monix 3K) / A 540 Grade B24

21) Values for 1.4571 / A 276 Type 316Ti

Material (Asia and Americas)		A 193 Grade B7/ B16 / A 540 Grade B24			A 193 Grade B7/ B16			10.9			--			A276 Type 316 Ti / Type 420		
Material (Europe)		1.7709/1.6772 (Monix 3K)			C35E+QT			8.8			A4-70			1.4571/1.4021		
Bearing bracket	Size	Stud <sup>18)</sup> 902.01			Stud <sup>16)</sup> 902.15			Hexagon head bolt 901.37			Stud <sup>16)</sup> 902.02			Impeller nut 922.01 and impeller screw 906		
		Quantity	Thread	Tightening torques <sup>(17)(18)</sup>	Quantity	Thread	Tightening torques <sup>(17)(18)</sup>	Quantity	Thread	Tightening torques <sup>(17)</sup>	Quantity	Thread	Tightening torques <sup>(17)(18)</sup>	Quantity	Thread	Tightening torques <sup>(17)</sup>
				[Nm]			[Nm]			[Nm]			[Nm]			
B03	80-230	12	M20	330 <sup>19)</sup> / 565 <sup>20)</sup>	4	M20	168	4	M12	77	4	M16	133	1	M20x1,5	250 <sup>21)</sup>
	80-280	16	M20	330 <sup>19)</sup> / 565 <sup>20)</sup>	4	M20	168	4	M12	77	4	M16	133	1	M20x1,5	250 <sup>21)</sup>
	80-360	20	M20	330 <sup>19)</sup> / 565 <sup>20)</sup>	4	M20	168	4	M12	77	4	M16	133	1	M20x1,5	250 <sup>21)</sup>
	100-180	12	M16	163 <sup>19)</sup> / 280 <sup>20)</sup>	4	M20	168	4	M12	77	4	M16	133	1	M20x1,5	250 <sup>21)</sup>
	100-230	12	M20	330 <sup>19)</sup> / 565 <sup>20)</sup>	4	M20	168	4	M12	77	4	M16	133	1	M20x1,5	250 <sup>21)</sup>
	100-280	16	M20	330 <sup>19)</sup> / 565 <sup>20)</sup>	4	M20	168	4	M12	77	4	M16	133	1	M20x1,5	250 <sup>21)</sup>
	150-230	12	M20	330 <sup>19)</sup> / 565 <sup>20)</sup>	4	M20	168	4	M12	77	4	M16	133	1	M20x1,5	250 <sup>21)</sup>
B05S	80-450	20	M24	565 <sup>19)</sup> / 970 <sup>20)</sup>	4	M24	290	4	M16	190	4	M16	133	1	M24x1,5	350 <sup>21)</sup>
	150-280	12	M24	565 <sup>19)</sup> / 970 <sup>20)</sup>	4	M24	290	4	M16	190	4	M16	133	1	M24x1,5	350 <sup>21)</sup>
	100-360	16	M24	565 <sup>19)</sup> / 970 <sup>20)</sup>	4	M24	290	4	M16	190	4	M16	133	1	M24x1,5	350 <sup>21)</sup>
	100-450	20	M24	565 <sup>19)</sup> / 970 <sup>20)</sup>	4	M24	290	4	M16	190	4	M16	133	1	M24x1,5	350 <sup>21)</sup>
	150-360	16	M24	565 <sup>19)</sup> / 970 <sup>20)</sup>	4	M24	290	4	M16	190	4	M16	133	1	M24x1,5	350 <sup>21)</sup>
	200-280	12	M24	565 <sup>19)</sup> / 970 <sup>20)</sup>	4	M24	290	4	M16	190	4	M16	133	1	M24x1,5	350 <sup>21)</sup>
B05L	150-450	20	M24	565 <sup>19)</sup> / 970 <sup>20)</sup>	4	M24	290	4	M16	190	4	M16	133	1	M30x1,5	600 <sup>21)</sup>
	150-501	30	M16	163 <sup>19)</sup> / 280 <sup>20)</sup>	4	M24	290	4	M16	190	4	M16	133	1	M30x1,5	600 <sup>21)</sup>
	200-360	16	M24	565 <sup>19)</sup> / 970 <sup>20)</sup>	4	M24	290	4	M16	190	4	M16	133	1	M30x1,5	600 <sup>21)</sup>
	200-450	20	M24	565 <sup>19)</sup> / 970 <sup>20)</sup>	4	M24	290	4	M16	190	4	M16	133	1	M30x1,5	600 <sup>21)</sup>
	200-401	24	M16	163 <sup>19)</sup> / 280 <sup>20)</sup>	4	M24	290	4	M16	190	4	M16	133	1	M30x1,5	600 <sup>21)</sup>
	200-501	24	M20	330 <sup>19)</sup> / 565 <sup>20)</sup>	4	M24	290	4	M16	190	4	M16	133	1	M30x1,5	600 <sup>21)</sup>
	250-401	24	M16	163 <sup>19)</sup> / 280 <sup>20)</sup>	4	M24	290	4	M16	190	4	M16	133	1	M30x1,5	600 <sup>21)</sup>
	250-501	24	M20	330 <sup>19)</sup> / 565 <sup>20)</sup>	4	M24	290	4	M16	190	4	M16	133	1	M30x1,5	600 <sup>21)</sup>

Material (Asia and Americas)		A 193 Grade B7/ B16 / A 540 Grade B24			A 193 Grade B7/ B16			10.9			--			A276 Type 316 Ti / Type 420		
Material (Europe)		1.7709/1.6772 (Monix 3K)			C35E+QT			8.8			A4-70			1.4571/1.4021		
Bearing bracket	Size	Stud <sup>18)</sup> 902.01			Stud <sup>16)</sup> 902.15			Hexagon head bolt 901.37			Stud <sup>16)</sup> 902.02			Impeller nut 922.01 and impeller screw 906		
		Quantity	Thread	Tightening torques <sup>17/18)</sup>	Quantity	Thread	Tightening torques <sup>17/18)</sup>	Quantity	Thread	Tightening torques <sup>17)</sup>	Quantity	Thread	Tightening torques <sup>17/18)</sup>	Quantity	Thread	Tightening torques <sup>17)</sup>
				[Nm]			[Nm]			[Nm]			[Nm]			
B05L	300-400	24	M20	330 <sup>19)</sup> / 565 <sup>20)</sup>	4	M24	290	4	M16	190	4	M16	133	1	M30x1,5	600 <sup>21)</sup>
	300-500	24	M20	330 <sup>19)</sup> / 565 <sup>20)</sup>	4	M24	290	4	M16	190	4	M16	133	1	M30x1,5	600 <sup>21)</sup>
B06	150-630	20	M24	565 <sup>19)</sup> / 970 <sup>20)</sup>	4	M24	290	4	M16	190	4	M20	270	1	M30x1,5	300 <sup>21)</sup> / 400 <sup>22)</sup>
	200-670	24	M24	565 <sup>19)</sup> / 970 <sup>20)</sup>	4	M24	290	4	M16	190	4	M20	270	1	M30x1,5	300 <sup>21)</sup> / 400 <sup>22)</sup>
	250-630	20	M24	565 <sup>19)</sup> / 970 <sup>20)</sup>	4	M24	290	4	M16	190	4	M20	270	1	M30x1,5	300 <sup>21)</sup> / 400 <sup>22)</sup>
	250-710	24	M24	565 <sup>19)</sup> / 970 <sup>20)</sup>	4	M24	290	4	M16	190	4	M20	270	1	M30x1,5	300 <sup>21)</sup> / 400 <sup>22)</sup>
	300-630	20	M24	565 <sup>19)</sup> / 970 <sup>20)</sup>	4	M24	290	8	M16	190	4	M20	270	1	M30x1,5	300 <sup>21)</sup> / 400 <sup>22)</sup>
	350-400	16	M24	565 <sup>19)</sup> / 970 <sup>20)</sup>	4	M24	290	8	M16	190	4	M20	270	1	M30x1,5	300 <sup>21)</sup> / 400 <sup>22)</sup>
	350-500	20	M24	565 <sup>19)</sup> / 970 <sup>20)</sup>	4	M24	290	8	M16	190	4	M20	270	1	M30x1,5	300 <sup>21)</sup> / 400 <sup>22)</sup>
	350-630	20	M24	565 <sup>19)</sup> / 970 <sup>20)</sup>	4	M24	290	8	M16	190	4	M20	270	1	M30x1,5	300 <sup>21)</sup> / 400 <sup>22)</sup>
B07	350-710	24	M24	565 <sup>19)</sup> / 970 <sup>20)</sup>	4	M24	290	10	M12	77	4	M20	270	1	M30x1,5	300 <sup>21)</sup> / 400 <sup>22)</sup>
	400-504	20	M24	565 <sup>19)</sup> / 970 <sup>20)</sup>	4	M24	290	10	M12	77	4	M20	270	1	M30x1,5	300 <sup>21)</sup> / 400 <sup>22)</sup>
	400-506	20	M24	565 <sup>19)</sup> / 970 <sup>20)</sup>	4	M24	290	10	M12	77	4	M20	270	1	M30x1,5	300 <sup>21)</sup> / 400 <sup>22)</sup>
	400-710	24	M24	565 <sup>19)</sup> / 970 <sup>20)</sup>	4	M24	290	10	M12	77	4	M20	270	1	M30x1,5	300 <sup>21)</sup> / 400 <sup>22)</sup>

22) Values for 1.4021 / A 276 Type 420

### 7.6.2 Tightening torques for the shaft nut

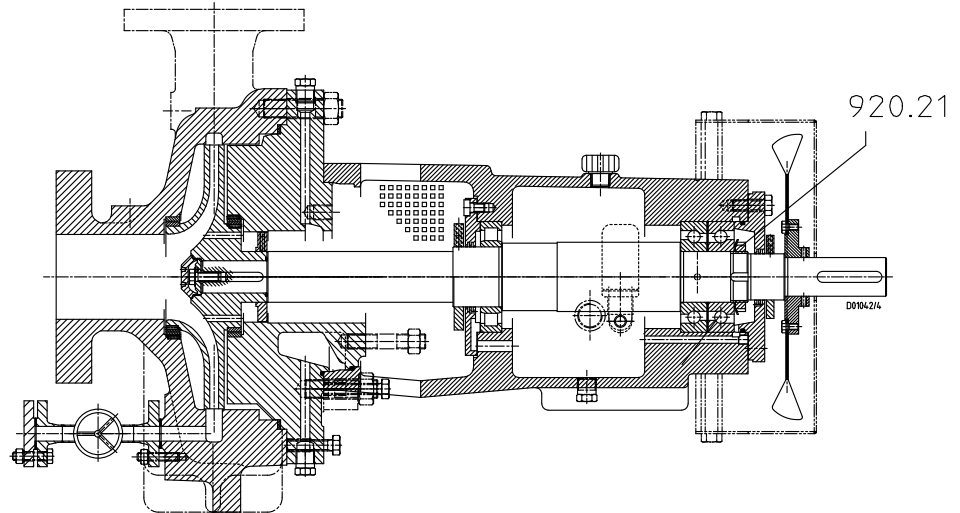

Fig. 14: Shaft nut position

Table 21: Shaft nut tightening torques

Position	Bearing bracket	Slotted round nut	Thread	Tightening torques [Nm]	
				M1 <sup>23)</sup>	M2 <sup>24)</sup>
920.21	B02	KM9	M 40x1,5	120	70
	B03	KM11	M 55x2	180	110
	B05	KM15	M 75x2	260	180
	B06	KM24	M 120x2	260	180
	B07	KM24	M 120x2	410	320

## 7.7 Spare parts stock

### 7.7.1 Ordering spare parts

Always quote the following data when ordering replacement or spare parts:

- Order number
- Order item number
- Type series
- Size
- Material variant
- Year of construction

Refer to the name plate for all data.

Also specify the following data:

- Part number and description (⇒ Section 9.1, Page 66)
- Quantity of spare parts
- Shipping address
- Mode of dispatch (freight, mail, express freight, air freight)

23) Loosen the bolted/screwed connection again after first tightening.

24) Final tightening torques

7.7.2 Recommended spare parts stock for 2 years' operation to DIN 24296

Table 22: Quantity of spare parts for recommended spare parts stock

Part No.	Description	Number of pumps (including stand-by pumps)						
		2	3	4	5	6 and 7	8 and 9	10 and more
210	Shaft	1	1	1	2	2	2	20 %
230	Impeller	1	1	1	2	2	2	20 %
23-2	Auxiliary impeller	1	1	1	2	2	2	20 %
320.02	Angular contact ball bearing (set)	1	1	2	2	2	3	25 %
322.01	Cylindrical roller bearing	1	1	2	2	2	3	25 %
330	Bearing bracket	-	-	-	-	-	1	2
502.01/.02 <sup>25)</sup>	Casing wear ring	2	2	2	3	3	4	50 %
503.01/.02 <sup>25)</sup>	Impeller wear ring	2	2	2	3	3	4	50 %
542.02	Throttling bush	1	1	2	2	2	3	30 %
-	Sealing elements	4	6	8	8	9	10	100 %
433	Mechanical seal, complete	1	1	2	2	2	3	25 %

25) If any

7.7.3 Interchangeability of pump components



Components featuring the same number in a column are interchangeable.

Table 23: Interchangeability of pump components

Bearing bracket	Size	Description																							
		Volute casing	Casing cover, uncooled	Casing cover, cooled	Shaft	Impeller	Impeller hub cap	Angular contact ball bearing	Cylindrical roller bearing	Bearing bracket	Bearing cover, pump end	Bearing cover, motor end	Joint ring	Mechanical seal	Seal cover	Casing wear ring, suction side	Casing wear ring, discharge side	Impeller wear ring, suction side	Impeller wear ring, discharge side	Thrower, pump end	Thrower, motor end	Oil thrower	Throttling bush	Impeller screw	Impeller nut
		102	161		210	230	260	320.02	322.01	330	360.01	360.02	411.10	433	471.01	502.01	502.02	503.01	503.02	507.01	507.02	508.01	542.01	906	922.01
B02S	25-180	1	1	1	1	1	-	1	1	1	1	1	1	1	1	1	1	1	1	1	1	1	1	-	1
	25-230	2	2	2	1	2	-	1	1	1	1	1	2	1	1	1	1	2	1	1	1	1	1	-	1
	40-180	3	1	1	1	3	-	1	1	1	1	1	1	1	1	2	2	2	2	1	1	1	1	-	1
	40-230	4	2	2	1	4	-	1	1	1	1	1	2	1	1	2	2	2	2	1	1	1	1	-	1
B02L	40-181	6	3	3	2	6	-	1	1	1	1	1	1	1	1	4	4	4	4	1	1	1	2	-	2
	40-280	5	5	5	2	5	-	1	1	1	1	1	3	1	1	3	5	3	5	1	1	1	2	-	2
	40-231	7	4	4	2	7	-	2	2	2	2	2	2	1	1	4	4	4	4	1	1	1	2	-	2
	40-281	8	5	5	2	8	-	2	2	2	2	2	3	1	1	4	5	5	5	1	1	1	2	-	2
	40-361	9	6	6	2	9	-	2	2	2	2	2	4	1	1	4	7	4	7	1	1	1	2	-	2
	50-180	10	7	7	2	10	-	2	2	2	2	2	1	1	1	5	5	5	5	1	1	1	2	-	2
B03	50-230	11	8	8	3	11	-	2	2	2	2	2	2	2	2	5	5	5	5	2	2	2	3	-	3
	50-280	12	9	9	3	12	-	2	2	2	2	2	3	2	2	5	5	5	5	2	2	2	3	-	3
	50-360	13	10	10	3	13	-	2	2	2	2	2	4	2	2	5	7	5	7	2	2	2	3	-	3
	50-450	14	11	11	3	14	-	2	2	2	2	2	5	2	2	5	9	5	9	2	2	2	3	-	3
	80-180	15	12	12	3	15	-	2	2	2	2	2	2	2	2	6	6	6	6	2	2	2	3	-	3
	80-230	16	12	12	3	16	-	2	2	2	2	2	2	2	2	6	6	6	6	2	2	2	3	-	3
	80-280	17	9	9	3	17	-	2	2	2	2	2	3	2	2	6	6	6	6	2	2	2	3	-	3
	80-360	18	13	13	3	18	-	2	2	2	2	2	4	2	2	6	7	6	7	2	2	2	3	-	3
	100-180	19	15	15	3	19	-	2	2	2	2	2	5	2	2	7	7	7	7	2	2	2	3	-	3
	100-230	20	16	16	3	20	-	2	2	2	2	2	5	2	2	7	7	7	7	2	2	2	3	-	3
	100-280	21	17	17	3	21	-	2	2	2	2	2	3	2	2	7	7	7	7	2	2	2	3	-	3
	150-230	22	20	20	3	22	-	2	2	2	2	2	2	2	2	9	9	9	9	2	2	2	3	-	3
	B05S	80-450	23	14	14	4	23	-	3	3	3	3	3	5	3	3	6	6	6	6	3	3	3	4	-
100-360		24	18	18	4	24	-	3	3	3	3	3	4	3	3	7	7	7	7	3	3	3	4	-	4
100-450		25	19	19	4	25	-	3	3	3	3	3	5	3	3	8	8	8	8	3	3	3	4	-	4
150-280		26	21	21	4	26	-	3	3	3	3	3	3	3	3	9	9	9	9	3	3	3	4	-	4
150-360		27	22	22	4	27	-	3	3	3	3	3	4	3	3	9	9	9	9	3	3	3	4	-	4
200-280		28	24	24	4	28	-	3	3	3	3	3	5	3	3	11	11	11	11	3	3	3	4	-	4
B05L	150-450	29	23	23	5	29	-	3	3	3	4	3	5	3	3	10	12	10	12	3	3	3	5	-	5
	150-501	32	27	27	5	32	-	3	3	3	3	3	6	3	3	11	11	11	11	3	3	3	5	-	5
	200-360	30	25	25	5	30	-	3	3	3	4	3	4	3	3	12	13	12	13	3	3	3	5	-	5
	200-401	33	28	28	5	33	-	3	3	3	3	3	7	3	3	14	14	14	14	3	3	3	5	-	5

Bearing bracket	Size	Description																							
		Volute casing	Casing cover, uncooled	Casing cover, cooled	Shaft	Impeller	Impeller hub cap	Angular contact ball bearing	Cylindrical roller bearing	Bearing bracket	Bearing cover, pump end	Bearing cover, motor end	Joint ring	Mechanical seal	Seal cover	Casing wear ring, suction side	Casing wear ring, discharge side	Impeller wear ring, suction side	Impeller wear ring, discharge side	Thrower, pump end	Thrower, motor end	Oil thrower	Throttling bush	Impeller screw	Impeller nut
		102	161		210	230	260	320.02	322.01	330	360.01	360.02	411.10	433	471.01	502.01	502.02	503.01	503.02	507.01	507.02	508.01	542.01	906	922.01
B05L	200-450	31	26	26	5	31	-	3	3	3	4	3	5	3	3	12	13	12	13	3	3	3	5	-	5
	200-501	34	29	29	5	34	-	3	3	3	3	3	6	3	3	15	15	15	15	3	3	3	5	-	5
	250-401	35	30	30	5	35	-	3	3	3	3	3	7	3	3	16	16	16	16	3	3	3	5	-	5
	250-501	36	31	31	5	36	-	3	3	3	3	3	6	3	3	17	17	17	17	3	3	3	5	-	5
	300-400	41	36	36	5	41	-	3	3	3	3	3	7	3	3	21	22	21	22	3	3	3	5	-	5
	300-500	42	37	37	5	42	-	3	3	3	3	3	8	3	3	25	26	25	26	3	3	3	5	-	5
B06	150-630	37	32	32	6	37	1	4	4	4	4	4	8	4	4	18	19	18	19	4	4	4	6	1	-
	200-670	38	33	33	6	38	1	4	4	4	4	4	9	4	4	20	20	20	20	4	4	4	6	1	-
	250-630	39	34	34	6	39	1	4	4	4	4	4	8	4	4	21	22	21	22	4	4	4	6	1	-
	250-710	40	35	35	6	40	1	4	4	4	4	4	9	4	4	23	24	23	24	4	4	4	6	1	-
	300-630	43	36	36	6	43	1	4	4	4	4	4	9	4	4	27	28	27	28	4	4	4	6	1	-
	350-400	44	37	37	7	44	1	4	4	4	4	4	7	4	4	29	30	27	31	4	4	4	6	1	-
	350-500	45	38	38	6	45	1	4	4	4	4	4	9	4	4	29	29	27	27	4	4	4	6	1	-
	350-630	46	36	36	6	46	1	4	4	4	4	4	8	4	4	32	32	33	33	4	4	4	6	1	-
B07	350-710	47	37	37	8	47	1	5	5	5	5	5	10	5	5	34	34	35	35	5	5	5	7	1	-
	400-504	48	38	38	8	48	1	5	5	5	5	5	11	5	5	34	34	35	35	5	5	5	7	1	-
	400-506	49	38	38	8	49	1	5	5	5	5	5	11	5	5	36	36	37	37	5	5	5	7	1	-
	400-710	50	37	37	8	50	1	5	5	5	5	5	10	5	5	38	39	37	40	5	5	5	7	1	-

## 8 Trouble-shooting

	 <b>WARNING</b>
	<p><b>Improper work to remedy faults</b> Risk of injury!</p> <p>▷ For any work performed to remedy faults, observe the relevant information given in this operating manual and/or in the product literature provided by the accessories manufacturer.</p>

If problems occur that are not described in the following table, consultation with the KSB customer service is required.

- A Pump delivers insufficient flow rate
- B Motor is overloaded
- C Excessive discharge pressure
- D Increased bearing temperature
- E Leakage at the pump
- F Excessive leakage at the shaft seal
- G Vibrations during pump operation
- H Impermissible temperature increase in the pump

Table 24: Trouble-shooting

A	B	C	D	E	F	G	H	Possible cause	Remedy <sup>26)</sup>
X	-	-	-	-	-	-	-	Pump delivers against an excessively high pressure.	Re-adjust to duty point. Check system for impurities. Fit a larger impeller. <sup>27)</sup> Increase the speed (turbine, I.C. engine).
X	-	-	-	-	-	X	X	Pump and piping are not completely vented or primed.	Vent and prime.
X	-	-	-	-	-	-	-	Supply line or impeller clogged	Remove deposits in the pump and/or piping.
X	-	-	-	-	-	-	-	Formation of air pockets in the piping	Alter piping layout. Fit vent valve.
X	-	-	-	-	-	X	X	Suction lift is too high/NPSH <sub>available</sub> (positive suction head) is too low.	Check/alter fluid level. Install pump at a lower level. Fully open the shut-off element in the suction line. Change suction line, if the friction losses in the suction line are too high. Check any strainers installed/suction opening. Observe permissible speed of pressure fall.
X	-	-	-	-	-	-	-	Air intake at the shaft seal	Clean barrier fluid duct, supply external barrier fluid if necessary, or increase barrier fluid pressure. Replace shaft seal.
X	-	-	-	-	-	-	-	Wrong direction of rotation	Check the electrical connection of the motor and the control system, if any.
X	-	-	-	-	-	-	-	<ul style="list-style-type: none"> <li>▪ Speed is too low. <sup>27)</sup></li> <li>▪ Operation with frequency inverter</li> <li>▪ Operation without frequency inverter</li> </ul>	<ul style="list-style-type: none"> <li>▪ Increase voltage/frequency at the frequency inverter in the permissible range. Check voltage.</li> </ul>
X	-	-	-	-	-	X	-	Impeller	Replace worn components by new ones.

26) Pump pressure must be released before attempting to remedy faults on parts which are subjected to pressure.

27) Contact KSB.



A	B	C	D	E	F	G	H	Possible cause	Remedy <sup>26)</sup>
-	X	-	-	-	-	X	-	Pump back pressure is lower than specified in the purchase order.	Re-adjust to duty point. In the case of persistent overloading, turn down impeller. <sup>27)</sup>
-	X	-	-	-	-	-	-	Density or viscosity of fluid handled higher than stated in purchase order	Contact KSB.
-	X	X	-	-	-	-	-	Speed is too high.	Reduce speed. <sup>27)</sup>
-	-	-	-	X	-	-	-	Defective gasket	Fit new gasket between volute casing and discharge cover.
-	-	-	-	-	X	-	-	Worn shaft seals	Fit new shaft seal. Check flushing liquid/barrier fluid.
-	-	-	-	-	X	-	-	Vibrations during pump operation	Correct the suction conditions. Re-align the pump. Re-balance the impeller. Increase pressure at the pump suction nozzle.
-	-	-	X	-	X	X	-	The pump set is misaligned.	Re-align.
-	-	-	X	-	X	X	-	Pump is warped or sympathetic vibrations in the piping.	Check the piping connections and secure fixing of pump; if required, reduce distances between the pipe clamps. Fix the pipelines using anti-vibration material.
-	-	-	X	-	-	X	-	Insufficient or excessive quantity of lubricant or unsuitable lubricant	Top up, reduce and/or change lubricant.
-	-	-	X	-	-	-	-	Non-compliance with specified coupling distance	Correct the distance according to the general arrangement drawing.
X	X	-	-	-	-	-	-	Motor is running on 2 phases only.	Replace the defective fuse. Check the electric cable connections.
-	-	-	-	-	-	X	-	Rotor out of balance	Clean the impeller. Re-balance the impeller.
-	-	-	-	-	-	X	-	Defective bearing(s)	Replace.
-	-	-	-	-	-	X	X	Flow rate too low	Increase the minimum flow rate.
-	-	-	-	-	X	-	-	Incorrect inflow of circulation liquid	Increase the free cross-section.

## 9 Related Documents

### 9.1 General assembly drawings with list of components

#### 9.1.1 Bearing brackets B02 to B05

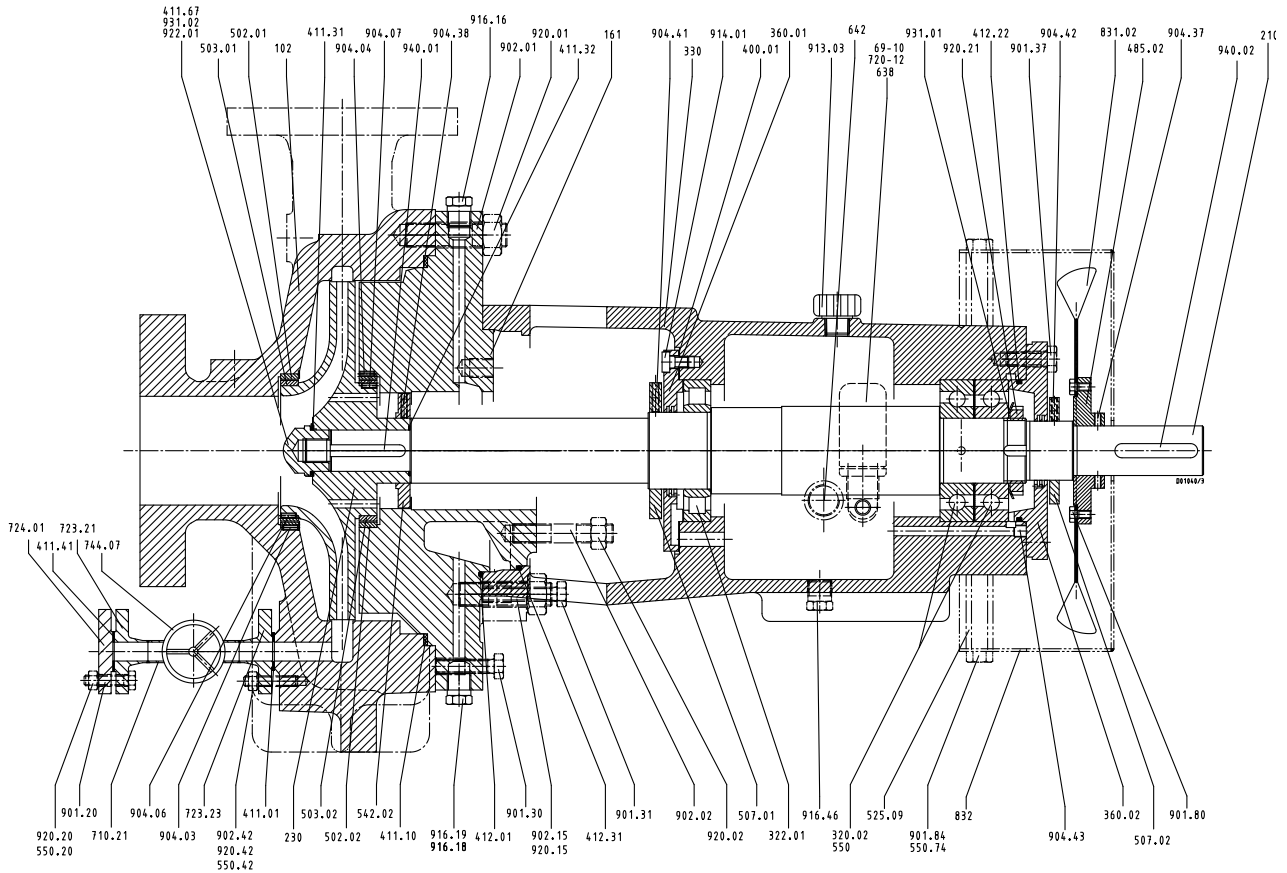

Fig. 15: Bearing brackets B02 to B05, a) uncooled and b) cooled

Table 25: List of components, bearing brackets B02 to B05

Part No.	Comprising	Description
102	102	Volute casing
	411.10	Joint ring
	502.01	Casing wear ring
	902.01	Stud
	904.03	Grub screw
	916.01 <sup>28)</sup>	Screw plug
	920.01	Hexagon nut
161	161	Casing cover
	411.10	Joint ring
	412.01/.31 <sup>29)</sup>	O-ring
	502.02	Casing wear ring
	901.30	Hexagon head bolt
	902.15	Stud
	904.04	Grub screw
	916.16	Screw plug

28) Not shown in drawing

29) For cooled design only

Part No.	Comprising	Description
161	920.15	Hexagon nut
210	210	Shaft
	920.21	Slotted round nut
	931.01	Lock washer
	940.01/.02	Key
230	230	Impeller
	931.02	Lock washer
	503.01/.02	Impeller wear ring
	904.06/.07	Grub screw
	411.31/.32/.67 <sup>30)</sup>	Joint ring
320.02/550 <sup>31)</sup>	Angular contact ball bearing	with disc 550 (adjusting washer)
322.01	322.01	Cylindrical roller bearing
330	330	Bearing bracket
	69.10	Protective cage
	360.01/.02	Bearing cover
	400.01	Gasket
	412.22	O-ring
	638	Constant level oiler
	642	Oil level sight glass
	710.21	Pipe
	901.31/.37	Hexagon head bolt
	913.03	Vent plug
	916.46	Screw plug
	914.01	Hexagon socket head cap screw
360.01/.02	360.01/.02	Bearing cover
	400.01	Gasket
	412.22	O-ring
	914.01	Hexagon socket head cap screw
502.01/.02 <sup>32)</sup>	502.01/.02	Casing wear ring
	904.03/.04 <sup>32)</sup>	Grub screw
503.01/.02 <sup>32)</sup>	503.01/.02	Impeller wear ring
	904.06/.07 <sup>32)</sup>	Grub screw
507.01/.02	507.01/.02	Thrower
	904.41/.42	Grub screw
542.02	542.02	Throttling bush
	904.38	Grub screw
638	638	Constant level oiler
70-3 <sup>30)</sup>	70-3	Drain line
	411.01	Joint ring
	902.42	Stud
	920.42	Hexagon nut
	550.42	Disc
	723.23	Flange
	744.07	Gate valve
	710.21	Pipe
723.21	Flange	

30) Optional

31) For bearing brackets B03 and B05 only

32) For impellers with balancing of axial thrust only

Part No.	Comprising	Description
70-3 <sup>30)</sup>	411.41	Joint ring
	724.01	Blind flange
	901.20	Hexagon head bolt
	920.20	Hexagon nut
	550.20	Disc
831.02 <sup>30)</sup>	831.02	Fan impeller
	832	Fan hood
	485.02	Fan hub
	904.37	Grub screw
922.01	922.01	Impeller nut
99-9 <sup>28)</sup>	99-9 <sup>28)</sup>	Set of sealing elements, complete

9.1.2 Bearing brackets B06 and B07

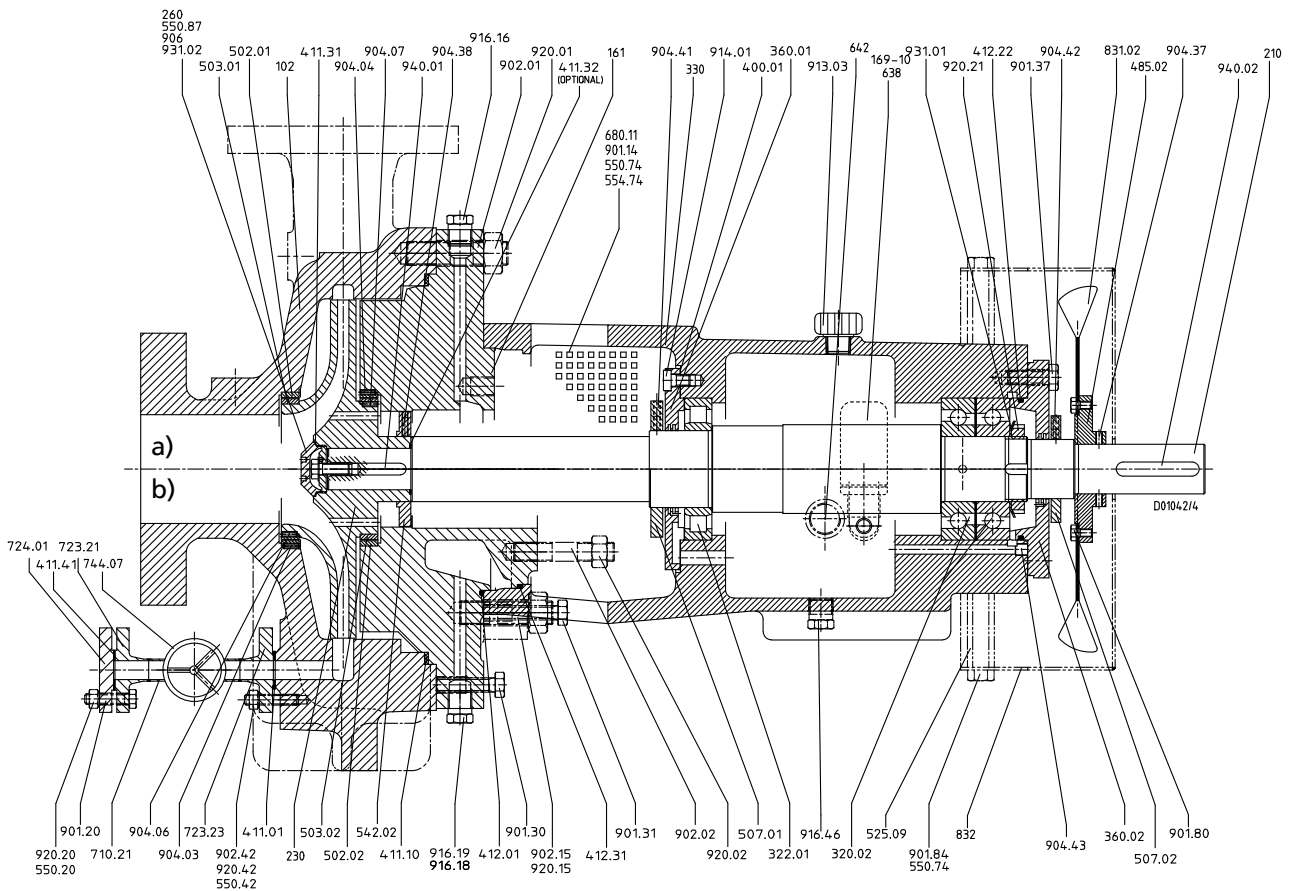

Fig. 16: Bearing brackets B06 and B07, a) uncooled and b) cooled

Table 26: List of components for pumps sets with bearing brackets B06 and B07

Part No.	Comprising	Description
102	102	Volute casing
	411.10	Joint ring
	502.01	Casing wear ring
	902.01	Stud
	904.03	Grub screw
	916.01 <sup>33)</sup>	Screw plug
	920.01	Hexagon nut

33) Not shown in drawing

Part No.	Comprising	Description
161	161	Casing cover
	411.10	Joint ring
	412.01/.31 <sup>34)</sup>	O-ring
	502.02 <sup>35)</sup>	Casing wear ring
	901.30	Hexagon head bolt
	902.15	Stud
	904.04 <sup>35)</sup>	Grub screw
	916.16	Screw plug
	920.15	Hexagon nut
210	210	Shaft
	920.21	Slotted round nut
	931.01	Lock washer
	940.01/.02	Key
230	230	Impeller
	503.01/.02	Impeller wear ring
	904.06/.07	Grub screw
	411.31/.32 <sup>36)</sup>	Joint ring
260	260	Impeller hub cap
320.02	320.02	Angular contact ball bearing
322.01	322.01	Cylindrical roller bearing
330	330	Bearing bracket
	69.10	Protective cage
	360.01/.02	Bearing cover
	400.01	Gasket
	412.22	O-ring
	638	Constant level oiler
	642	Oil level sight glass
	710.21	Pipe
	901.31/.37	Hexagon head bolt
	913.03	Vent plug
	916.46	Screw plug
360.01/.02	360.01/.02	Bearing cover
	400.01	Gasket
	412.22	O-ring
	914.01	Hexagon socket head cap screw
502.01/.02	502.01/.02	Casing wear ring
	904.03/.04 <sup>35)</sup>	Grub screw
503.01/.02	503.01/.02	Impeller wear ring
	904.06/.07 <sup>35)</sup>	Grub screw
507.01/.02	507.01/.02	Thrower
	904.41/.42	Grub screw
542.02	542.02	Throttling bush
	904.38	Grub screw
550.87	550.87	Disc
638	638	Constant level oiler

34) For cooled design only  
35) For impellers with balancing of axial thrust only  
36) Optional

Part No.	Comprising	Description
70-3 <sup>36)</sup>	70-3 <sup>36)</sup>	Drain line
	411.01	Joint ring
	902.42	Stud
	920.42	Hexagon nut
	550.42	Disc
	723.23	Flange
	744.07	Gate valve
	710.21	Pipe
	723.21	Flange
	411.41	Joint ring
	24.01	Blind flange
	901.20	Hexagon head bolt
	920.20	Hexagon nut
	550.20	Disc
831.02 <sup>36)</sup>	831.02 <sup>36)</sup>	Fan impeller
	832	Fan hood
	485.02	Fan hub
	904.37	Grub screw
906	906	Impeller screw
931.02	931.02	Lock washer
99-9 <sup>33)</sup>	99-9 <sup>33)</sup>	Set of sealing elements, complete

9.1.3 Design variants

Table 27: Design variants

Design	Detailed view
Design with coolable bearing bracket	
Design with thrower	

Design	Detailed view
Design with plug	
Design with welded drain	
Design with bearings in tandem arrangement	

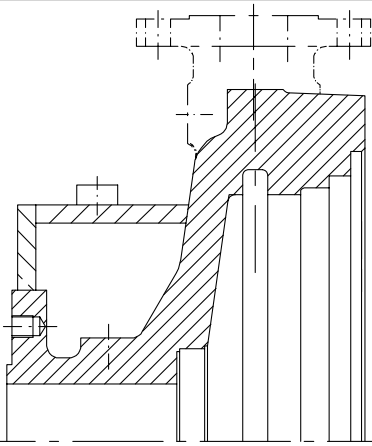
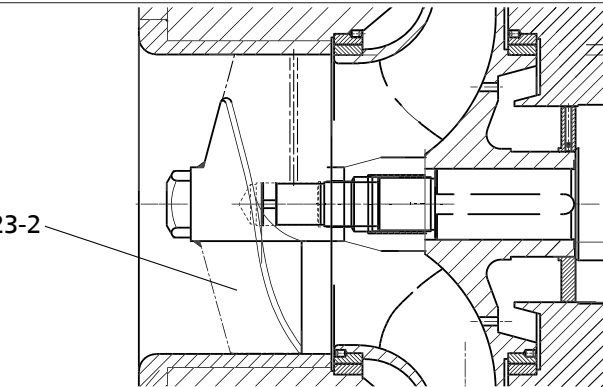
Design	Detailed view
<p>Design with heatable casing</p>	 <p style="text-align: center;">D01126</p>
<p>Design with auxiliary impeller</p>	 <p>23-2</p>



## 10 EU Declaration of Conformity

Manufacturer: **KSB SE & Co. KGaA**  
**Johann-Klein-Straße 9**  
**67227 Frankenthal (Germany)**

The manufacturer herewith declares that the product:

### RPH

KSB order number: .....

- is in conformity with the provisions of the following Directives as amended from time to time:
  - Pump (set): Machinery Directive 2006/42/EC

The manufacturer also declares that

- the following harmonised international standards have been applied:
  - ISO 12100
  - EN 809
- Applied national technical standards and specifications, in particular:
  - DIN EN ISO 13709

Person authorised to compile the technical file:

Name  
Function  
Address (company)  
Address (Street, No.)  
Address (post or ZIP code, city) (country)

The EU Declaration of Conformity was issued in/on:

Place, date

.....<sup>37)</sup>.....

Name  
Function  
Company  
Address

---

37) A signed, legally binding EU Declaration of Conformity is supplied with the product.

---



## Index

### A

Abrasive fluids 40  
 Auxiliary connections 26

### B

Back pull-out unit 50  
 Bearing temperature 44  
 Bearings 17

### C

Certificate of decontamination 74  
 Clearances 45  
 Commissioning 31  
 Constant level oiler 31  
 Coupling 20, 45

### D

Design 17, 19  
 Designation 16  
 Direction of rotation 30  
 Disassembly 49  
 Disposal 15

### E

Event of damage 7  
     Ordering spare parts 60  
 Explosion protection 11, 21, 27, 29, 30, 34, 35, 36, 37,  
 38, 39, 42, 43, 44, 45, 47

### F

Faults  
     Causes and remedies 64  
 Fields of application 9  
 Filter 24, 47  
 Final check 34  
 Flow rate 39  
 Fluid handled  
     Density 40  
 Forces and moments 25  
 Frequency of starts 39  
 Function 19

### H

Heating 36  
 Heating speed 36  
 Heating up 36

### I

Impeller type 17

Installation

    Installation on a foundation 22

Installation at site 21

Intended use 9

Interchangeability of pump components 62

### K

Keeping warm 36

Key to safety symbols/markings 8

### L

List of components 66, 68

### M

Maintenance 43

Mechanical seal 37

Monitoring equipment 12

### N

Name plate 16

Noise characteristics 19

### O

Oil lubrication

    Intervals 47

    Oil quality 47

Operating limits 38

Order number 7

Other applicable documents 7

### P

Partly completed machinery 7

Piping 23

Preservation 14, 41

Priming and venting 34

Product description 16

Pump casing 17

### R

Return to supplier 14

Returning to service 41

Running noises 43, 44

### S

Safety 9

Safety awareness 10

Scope of supply 19

Shaft seal 17

Shutdown 38, 41

Spare part  
    Ordering spare parts 60  
Special accessories 20  
Start-up 37  
Storage 14, 41

## **T**

Temperature difference 36  
Temperature limits 11, 12  
Tightening torques 57  
    Shaft nut 60  
Transport 13

## **W**

Warnings 8  
Warranty claims 7  
Water cooling 34, 35









**KSB SE & Co. KGaA**

Johann-Klein-Straße 9 • 67227 Frankenthal (Germany)

Tel. +49 6233 86-0

[www.ksb.com](http://www.ksb.com)